



Public Works - Administration

505 4th Ave S
Minneapolis, MN 55415

www.minneapolismn.gov

Technical Memorandum

To: All Entities working in City of Minneapolis Right-of-Way

**From: Public Works Administration – Right-Of-Way Management
Bryan Dodds, P.E. – Deputy Director / City Engineer**



Date June 5, 2023

**Subject: Americans with Disabilities Act (ADA) Pedestrian
Curb Ramp Design, Construction, and Repair**

Memo Overview

Introduction

Under the Americans with Disabilities Act (ADA) Title II regulation, it is required of the City of Minneapolis to ensure that accessibility within public right-of-way meets current federal and state legislative mandates. Specifically, Title II requires that all state and local governments maintain an ADA transition plan and provide accessible facilities and reasonable modifications, regardless of the funding source. The City of Minneapolis, Department of Public Works ensures accessible facilities by managing the use, design, and construction of sidewalks, curb ramps, traffic signals, street crossings, and roadways. An overview of the guidelines and initiatives by Public Works to accomplish this requirement can be found in the [Public Works ADA Transition Plan](#), [City of Minneapolis Street Design Guide](#) and the [Transportation Action Plan](#).

Purpose

This Technical Memorandum sets forth the requirements for ADA pedestrian curb ramp design, construction, repairs, and documentation within City of Minneapolis public right-of-way. The City models ADA curb ramp designs and policy guidelines from the Minnesota Department of

Transportation (MnDOT). This document is an update and modernization of the City Engineer's memo to the franchise agreement utility agencies in 2015 (Attachment E).

Implementation

The requirements described in this Technical Memorandum and attachments shall be incorporated into all design, new construction, reconstruction, and alteration threshold projects, including:

- All Public Works projects
- All work within the public right-of-way undertaken by other public agencies and private entities whether by permit or by agreement

Questions

The Right-of-Way (ROW) Management group oversees the coordination and management of ADA compliance within the public right-of-way. For information and questions regarding this technical memorandum, contact:

Aaron Johnson - Public Works Admin - Project Manager at aaron.johnson@minneapolismn.gov

Other Public Works contacts:

Brandon Schnabel - Sidewalk Inspections at brandon.schnabel@minneapolismn.gov

Utility Connections at pwutility.connections@minneapolismn.gov

Scott Kramer - Lane Use/Obstruction Permit at scott.kramer@minneapolismn.gov

Gary Long - Street Maintenance at gary.long@minneapolismn.gov

Lawrence Matsumoto, MN PE - Paving Construction at larry.matsumoto@minneapolismn.gov

Jeremy Strehlo, MN PE – Surface Water and Sewers at jeremy.strehlo@minneapolismn.gov

Ethan Van Offelen - ROW Management at ethan.vanoffelen@minneapolismn.gov

Attachments

Attachment A: Curb Ramp Standard Plan 5-297.25

Attachment B: ADA Curb Ramp Checklist

Attachment C: Department of Justice / Department of Transportation Joint Technical Assistance

Attachment D: Level 2 and 3 ADA Intersection Detail Attachment

Attachment E: 2015 City Engineer's (Steve Kotke) Memo

Table of Contents

I.	Design and Construction Requirements.....	4
A.	Thresholds of ADA Curb Ramp Replacement or Installation.....	4
1.	Impacts to Non-ADA Compliant Curb Ramps.....	4
2.	New Construction.....	4
3.	Street Reconstruction.....	4
4.	Resurfacing Alteration Threshold.....	4
B.	Curb Ramp Design.....	5
1.	Scoping of work.....	5
C.	Curb Ramp Construction.....	6
1.	Curb, Gutter, and Street Construction.....	6
2.	V-Curb.....	6
3.	Public and Private Utility Structures.....	6
4.	Catch Basins.....	7
II.	Permit Requirements.....	7
III.	Post-Construction.....	8
A.	Inspections.....	8
B.	Enforcement.....	8
	Attachment A.....	10
	Attachment B.....	17
	Attachment C.....	19
	Attachment D.....	29
	Attachment E.....	35

I. Design and Construction Requirements

A. Thresholds of ADA Curb Ramp Replacement or Installation

The ADA requires that all work meeting the alteration threshold, at a minimum, provide or update curb ramps before or at the time of the alteration work. Public Works recognizes the following as thresholds for the project constructor or permittee to ensure the curb ramps in the project area are ADA compliant through inspection, modification, or replacement as necessary:

1. Impacts to Non-ADA Compliant Curb Ramps

Any impact or alteration, including but not limited to excavation, potholing, panel replacement, saw cutting, manhole or utility box adjustments or placements, trenching, pole removals, etc. that occur on a curb ramp that is not ADA compliant will require a reconstruction of the quadrant to meet MnDOT ADA specifications (Attachment A). All development projects impacting City sidewalk must submit plans in the design phase showing they are meeting ADA accessibility requirements.

2. New Construction

All new construction, whether public or private, shall be scoped to identify and address pedestrian needs, in accordance with the MnDOT ADA specifications and the [City of Minneapolis Street Design Guide](#).

3. Street Reconstruction

The City requires that all street reconstruction projects include ADA compliant curb ramps, correction of non-ADA compliant sidewalks and driveways, improvements to address sidewalk gaps within the existing network, and for all signalized intersections to be upgraded with Accessible Pedestrian Signals (APS).

4. Resurfacing Alteration Threshold

Work types that meet the resurfacing alteration threshold are determined by the Department of Justice (DOJ) / Federal Highway Administration (FHWA) Joint Technical Assistance and cannot be re-categorized by the City of Minneapolis or MnDOT (Attachment C). Alterations are defined by the DOJ as changes that affect or could affect the usability of all or part of a building or facility. The DOJ classifies resurfacing as an alteration that requires curb ramps to be ADA compliant if it involves work on a street or roadway spanning from one intersection to another or through a pedestrian crossing and includes additional material to the road surface, with or without milling. Examples set by the DOJ include, but are not limited to, a new layer of asphalt, concrete pavement rehabilitation and reconstruction, open-graded surface course, micro-surfacing, and thin lift overlays.

Work types that **do not** initiate the threshold for ensuring curb ramp compliance are, but are not limited to:

- Impacts to ADA compliant curb ramps. Compliant ramps require replacement of impacted panels only, a full curb ramp reconstruct is not required.
- Routine maintenance of public and private utilities in the roadway that intersects the pedestrian crossing that does not impact the curb ramp.
- Routine maintenance of road surface that serve solely to seal and protect the road surface, improve friction, and control splash and spray. Examples include painting or striping lanes, crack filing and sealing, surface sealing, chip seals, slurry seals, fog seals, joint repairs, and pavement patching.
- Ramps that will be reconstructed as part of a street reconstruction project within the next full construction season.

If unsure of whether the work type triggers curb ramp upgrades, contact ROW Management or Sidewalk Inspections.

B. Curb Ramp Design

Curb ramps shall be built in accordance with MnDOT standards plans 5-297.250 (Attachment A), which can be found on [MnDOT's Accessibility Design Guidance](#) website. When ramps are unable to be built to current MnDOT specifications, ramps shall be built to the maximum extent feasible of the specifications and documented in the design/plans and sent to ROW Management. All applicable designs and plan sets must be signed and reviewed by a Minnesota Licensed Professional Engineer as prescribed under Chapter 1805 of the Minnesota State Statute. Ramps will be inspected post-construction, using a standard form (Attachment B), based on dimensions and slopes of the PAR, landing, ramp(s), flares, flowline, and gutter in-slope; as well as size of discontinuities, drainage issues, surface variations, truncated dome specifications, and proper size and use of joints.

1. Scoping of work

For Public Works projects, Project Engineers shall identify all accessible pedestrian facility needs in the preliminary design phase of project development for all new construction, reconstruction, and alteration projects. Field walks and predesign efforts shall capture removal limits; level 1, 2, & 3 ramp designs; and types of curb ramps that will be required during construction. Level 1 designs can be built to MnDOT standard plates and do not require further surveying or design tabulations. Level 2 and 3 designs have horizontal and vertical constraints, respectively, that will require a full design (see Attachment C for examples of level 2 and 3 requirements). Further information on best design practices and project scoping can be found on [MnDOT's ADA Accessibility](#) webpage.

All designs by other public agencies, developers, private utilities, and privately contracted sidewalk work not part of a Public Works project shall identify level 1, 2, & 3 curb ramps in their project scope prior to applying for a Sidewalk Permit. Level 2 and 3 ramps will require a full design for review by Sidewalk Inspections before a permit is approved. For assistance with determining the level of ramp design required please contact ROW Management. Combined directional ramps or two perpendicular ramps at a quadrant are the preferred ramp types for all level 1, 2, & 3 designs if the ramp can be constructed meeting MnDOT compliance standards. Choose ramp type to best accomplish compliance standards after the combined directional has been ruled out for meeting ADA compliance.

C. Curb Ramp Construction

All construction zones must provide a Temporary Pedestrian Access Route (TPAR) when a pedestrian access route is disrupted, closed, or relocated during construction, maintenance work, or other temporary condition. Signage and devices, as necessary, shall be provided to direct pedestrians safely through or around the work zone.

Other construction considerations:

1. Curb, Gutter, and Street Construction

All information regarding restoration requirements for restoring curb and gutter can be found at <https://www2.minneapolismn.gov/business-services/doing-business-with-the-city/construction-infrastructure/road-standard-plates/>. Contact the Street Maintenance department with questions.

2. V-Curb

The use of v-curb between the curb ramp or sidewalk and private property introduces long-term maintenance concerns to the City and should be avoided when possible. It is recommended to use concrete or bituminous tapers of less than 5% running slope where curb ramps are adjacent to parking lots instead of v-curbs to prevent tripping hazards. Negotiated temporary construction easements for grading out the slope should be considered as an alternative to v-curbs.

3. Public and Private Utility Structures

Surface-level elements such as manhole covers, fire hydrants, utility poles, utility vault covers or signal handholes should be kept out of the curb ramp landing and ramp areas to the greatest extent feasible. Where there are utility structures being installed in or around the curb ramp, they must not inhibit the right-of-way from being ADA compliant i.e. handholes and vaults should not cause more than a ¼ inch vertical discontinuity in the Pedestrian Access Route (PAR) and shall not keep the PAR from maintaining a minimum 3' clear width of non-slip walking surface. The preference of placement for these structures in the curb ramp and surrounding area is as follows:

1. In boulevard adjacent to sidewalk.
2. In any sidewalk area that is not considered a ramp or a landing area.
3. In the landing of the curb ramp.
4. In the ramp of the curb ramp.
5. No utility structures should be placed in the truncated domes.

All utility structures shall be installed in coordination with surrounding utilities. Contact Gopher State One Call (811) before starting any excavation.

4. Catch Basins

a. Proposed catch basins

For all projects, the design and location of proposed catch basins shall not impact ADA curb ramp compliance.

b. Existing catch basins

For projects that include ADA curb ramp upgrades, the location of existing catch basins must be considered. If an existing catch basin is located within 1' of the 0" curb of the ramp or is within the path of travel any modifications to the catch basin or casting including removing the curb box shall be discussed with Public Works: Surface Water and Sewers. An ADA approved grate should be discussed as an option for achieving optimal ramp design and ADA compliance. Additional drainage structures may be required as ADA compliant grates capture less water than standard grates. If the catch basin is not a candidate for an ADA approved grate an alternative design will be discussed and agreed upon with ROW Management. Catch basins that are impacted by ADA curb ramp work shall be inspected for condition and repairs prior to ramp construction.

II. Permit Requirements

The replacement of curb ramps must be indicated as part of the Sidewalk Construction and Repair Inspection (Sidewalk) permit. A Sidewalk permit shall be obtained for all work performed in the City's right-of-way involving the replacement of sidewalk panels. Application for the Sidewalk permit shall be submitted by the sidewalk contractor online using the City's [Sidewalk Construction and Repair Inspection Permit](#) form.

All City crews and contractor's working for the city shall follow the same procedure/ processes as above. This also includes external agencies working inside Minneapolis including, but not limited to, the Federal Highway Administration, MnDOT, Minneapolis Park and Recreation Board, Hennepin County, Metropolitan Council, University of Minnesota, and Minnesota Pollution Control Agency. All work done for development projects disrupting the sidewalk or curb ramps within the city limits shall obtain a Sidewalk permit before pouring concrete. An [Obstruction permit](#) must be obtained through Lane Use for sidewalk closures. A Sidewalk permit must be obtained before an Obstruction permit will be granted. All contractors doing subsequent utility work impacting the City's sidewalk must first obtain a [Utility](#)

[Connections permit](#) prior to all other ROW permits. Documents and plans detailing locations of curb ramp upgrades, as outlined in Section I.B.1, are required for issuance of a Sidewalk permit. Any permitted curb ramp that cannot be built to MnDOT standard plans and/or requires a ramp that cannot meet MnDOT ADA standards due to spatial limitations or utility constraints must be accompanied with a plan detailing to the maximum extent feasible that the ramp was designed to comply with standards in the permit request.

III. Post-Construction

A. Inspections

All curb ramps will be inspected following completion and results of inspection are to be documented. Documentation is cataloged for future planning efforts and recorded in a database maintained by ROW Management. For all curb ramp constructions not built as part of a City project, ROW Management will inspect and document the work for ADA compliance. All work done for City projects will be inspected and documented by the Project Engineer's delegated staff.

B. Enforcement

Sidewalk Inspectors are authorized to issue citations and give orders to correct ([Minneapolis Code of Ordinances, Title 1, Chapter 2.20](#)) for violations to offenses in [Minneapolis Code of Ordinances, Title 17, Chapter 437](#).

The most common issues related to this memorandum that violate Title 17, Chapter 437:

- Failure to obtain a Sidewalk permit.
- Constructing a non- ADA compliant curb ramp.
- Not completing the documentation requirements for level 2 and 3 designs.

Penalties for failing to obtain a Sidewalk Construction Permit are outlined in [Chapter 437.20](#) including obtaining a new permit, doubling of said permit fee, doubling of all other permit fees associated with work being done, payment of any damages, and future denial of permits. Penalties for constructing a non- ADA compliant curb ramp or not providing level 2 and 3 designs are enforceable under [Chapter 437.20](#) and [Chapter 437.30](#) as a reasonable condition for acceptance of permitted work as ADA compliance is mandated by the Department of Justice. Failure to comply with these provisions may result in an order to correct, permit cancelation, administrative fines, denial of future permits, doubling of permit fees, or administrative fines. If a ramp is not compliant due to a contractor's performance but could be, the ramp will need to be made compliant. The remediated work shall be done within 30 days of the final non-compliance inspection or an agreed upon timeline with Sidewalk Inspections when circumstances require an extended timeline. If there is an immediate safety concern, appropriate signage will be placed to provide for public safety and work to address the safety concern shall begin immediately. All costs for correction of these violations will be the responsibility of the permittee.

Public Works Division Director Approval

DocuSigned by:
Don Elwood
5567AD13D57A454...

5/9/2023

Donald Elwood
Director of Transportation Engineering & Design

Date

DocuSigned by:
Annika M. Bankston
3597D71D5395461...

5/8/2023

Annika Bankston
Director of Water Treatment & Distribution Services

Date

DocuSigned by:
Angella Craft
DA3A2B816892447...

5/8/2023

Angella Craft
Director of Surface Water & Sewers

Date

DocuSigned by:
Jenifer Hager
09A144E7D066486...

5/10/2023

Jenifer Hager
Director of Transportation Planning & Programming

Date

DocuSigned by:
Allan Klugman
2E419A760404473...

5/8/2023

Allan Klugman
Director of Traffic & Parking Services

Date

DocuSigned by:
Joe Paumen
036854568A81419...

5/15/2023

Joseph Paumen
Director of Transportation Maintenance & Repair

Date

DocuSigned by:
Bryan Dodds
9E133E36C89445E...

5/23/2023

Bryan Dodds
Deputy Director / City Engineer

Date

Attachment A:

MnDOT Curb Ramp Standard Plan 5-297.250

City of Minneapolis: Public Works

ROW Management

2023

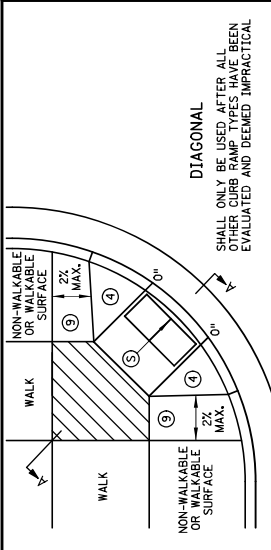

DIAGONAL

SHALL ONLY BE USED AFTER ALL OTHER CURB RAMP TYPES HAVE BEEN EVALUATED AND DEEMED IMPRACTICAL.

FAN

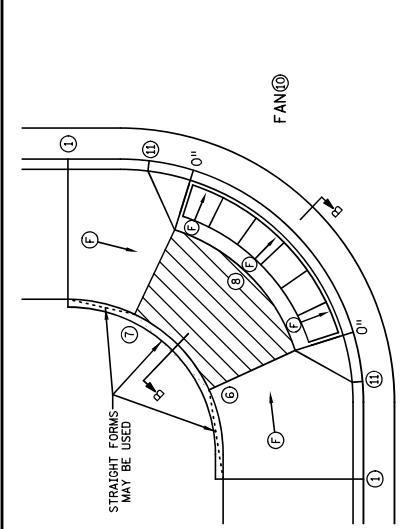

MODIFIED FAN

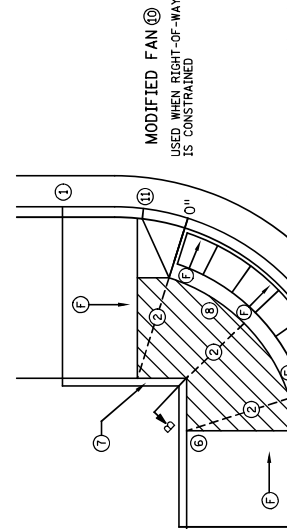

DEPRESSED CORNER

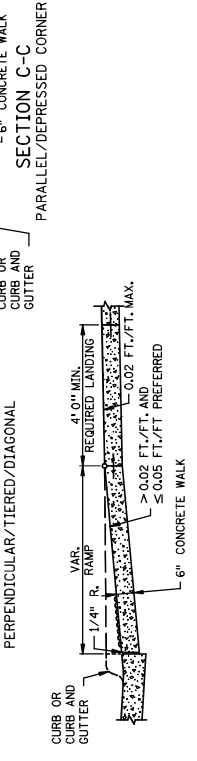
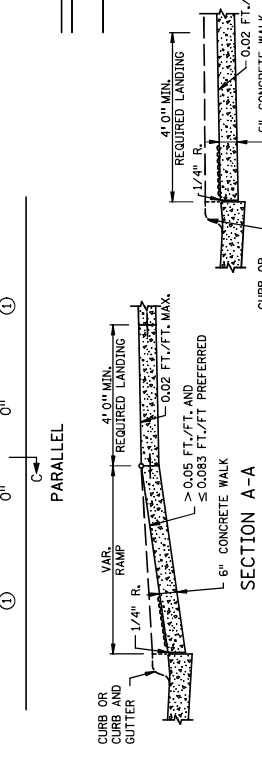
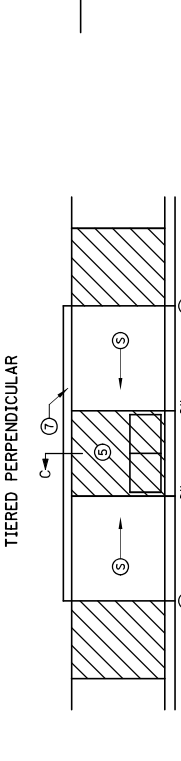
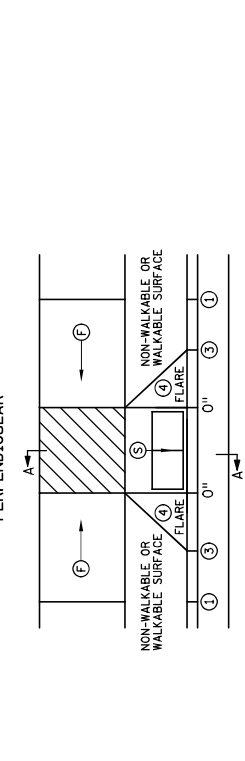
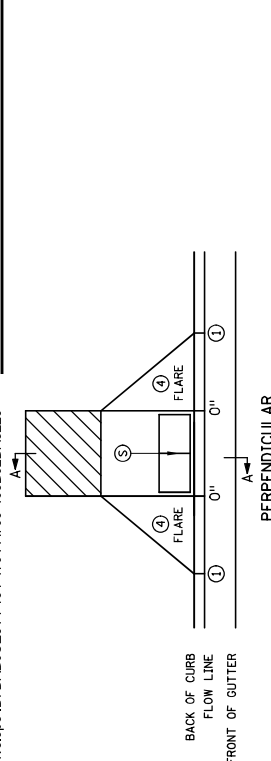
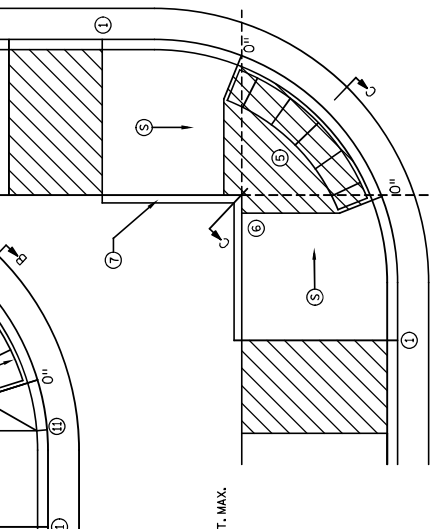

PERPENDICULAR

TIERED PERPENDICULAR

PARALLEL

PERPENDICULAR/TIERED/DIAGONAL

FAN

LANDINGS SHALL BE LOCATED ANYWHERE THE PEDESTRIAN ACCESS ROUTE (PAR) CHANGES DIRECTION. AT THE TOP OF RAMPS THAT HAVE RUNNING SLOPES GREATER THAN 5.0%, INITIAL CURB RAMP LANDINGS SHALL BE CONSTRUCTED WITHIN 15' FROM THE BACK OF CURB. THE INITIAL RAMP RUNNING SLOPE IS GREATER THAN 5.0%, THE INITIAL RAMP RUNNING SLOPE IS GREATER THAN 5.0%.

CONTRACTION JOINTS SHALL BE CONSTRUCTED ALONG ALL GRADE BREAKS WITHIN THE PAR. 1/4\"/>

TO ENSURE RAMPS AND LANDINGS ARE PROPERLY CONSTRUCTED, ALL INITIAL LANDINGS AT A TOP OF A RAMPED SURFACE (RUNNING SLOPE GREATER THAN 2%) SHALL BE FORMED AND PLACED SEPARATELY FOR ALL SEPARATELY POURED INITIAL LANDINGS. SIDEWALK REINFORCEMENT DETAILS ON SHEET 6 OF 6 WHEN SIDEWALK IS AT BACK OF CURB. TOP OF CURB SHALL MATCH PROPOSED ADJACENT WALK GRADE.

ALL RAMP TYPES SHOULD HAVE A MINIMUM 3\"/>

4\"/>

1 MATCH FULL HEIGHT CURB.
 2 4\"/>

3 3\"/>

4 SEE SHEET 4 OF 6 TYPICAL SIDE TREATMENT OPTIONS FOR DETAILS ON FLARES AND RETURNED CURBS.

5 DETECTABLE WARNINGS MAY BE PART OF THE 4\"/>

6 THE GRADE BREAK SHALL BE PERPENDICULAR TO THE BACK OF WALK. THIS WILL ENSURE THAT THE GRADE BREAK IS PERPENDICULAR TO THE DIRECTION OF TRAVEL. (TYPICAL FOR ALL) IF USED, SHALL BE PLACED OUTSIDE THE SIDEWALK LIMIT WHEN RIGHT-OF-WAY ALLOWS.

7 WHEN ADJACENT TO PARKING LOTS, CONCRETE OR BITUMINOUS TAPERS LESS THAN 12\"/>

8 A 7\"/>

9 PAVE FULL WALK WIDTH.
 10 5\"/>

BACK OF CURB FLOW LINE FRONT OF GUTTER

FLARE

NON-WALKABLE OR WALKABLE SURFACE

FLARE

NON-WALKABLE OR WALKABLE SURFACE

FLARE

NON-WALKABLE OR WALKABLE SURFACE

FLARE

NON-WALKABLE OR WALKABLE SURFACE

FLARE

NON-WALKABLE OR WALKABLE SURFACE

FLARE

NON-WALKABLE OR WALKABLE SURFACE

FLARE

NON-WALKABLE OR WALKABLE SURFACE

FLARE

NON-WALKABLE OR WALKABLE SURFACE

FLARE

NON-WALKABLE OR WALKABLE SURFACE

FLARE

NON-WALKABLE OR WALKABLE SURFACE

FLARE

NON-WALKABLE OR WALKABLE SURFACE

FLARE

NON-WALKABLE OR WALKABLE SURFACE

FLARE

NON-WALKABLE OR WALKABLE SURFACE

FLARE

NON-WALKABLE OR WALKABLE SURFACE

FLARE

NON-WALKABLE OR WALKABLE SURFACE

FLARE

NON-WALKABLE OR WALKABLE SURFACE

FLARE

NON-WALKABLE OR WALKABLE SURFACE

FLARE

NON-WALKABLE OR WALKABLE SURFACE

FLARE

NON-WALKABLE OR WALKABLE SURFACE

FLARE

NON-WALKABLE OR WALKABLE SURFACE

FLARE

NON-WALKABLE OR WALKABLE SURFACE

FLARE

NON-WALKABLE OR WALKABLE SURFACE

FLARE

NON-WALKABLE OR WALKABLE SURFACE

FLARE

NON-WALKABLE OR WALKABLE SURFACE

FLARE

NON-WALKABLE OR WALKABLE SURFACE

FLARE

NON-WALKABLE OR WALKABLE SURFACE

FLARE

NON-WALKABLE OR WALKABLE SURFACE

FLARE

NON-WALKABLE OR WALKABLE SURFACE

FLARE

NON-WALKABLE OR WALKABLE SURFACE

FLARE

STANDARD PLAN 5-297.250 1 OF 6

APPROVED: 11-04-2021

REVISED:

STATE PROJ. NO. (TH) SHEET NO. OF SHEETS



THOMAS J. REISCH STATE DESIGN ENGINEER

REVISION: 11-04-2021

APPROVED: 11-04-2021

OPERATIONS DIVISION

PEDESTRIAN CURB RAMP DETAILS

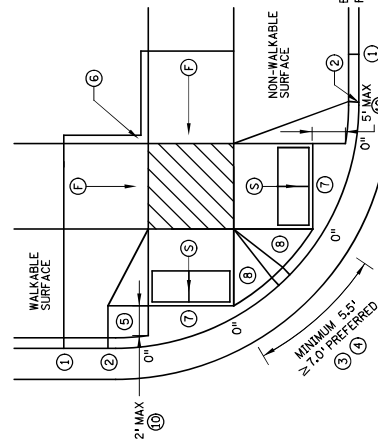

COMBINED DIRECTIONAL

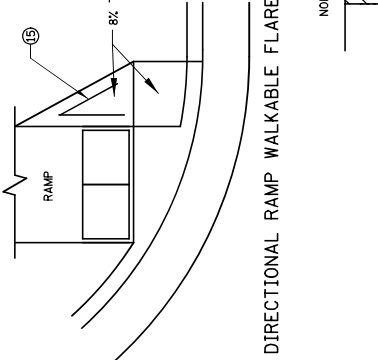

DIRECTIONAL RAMP WALKABLE FLARE

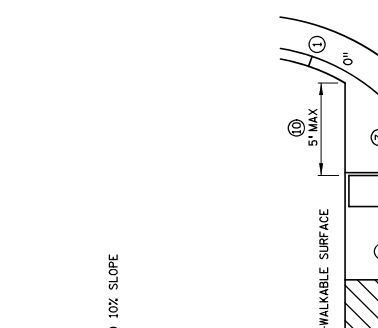

STANDARD ONE-WAY DIRECTIONAL

IF NON-CONCRETE BLVD. IS CONSTRUCTED AND IS LESS THAN 2' IN WIDTH AT TOP OF CURB TRANSITION, PAVE CONCRETE RAMP WIDTH TO ADJACENT BACK OF CURB.

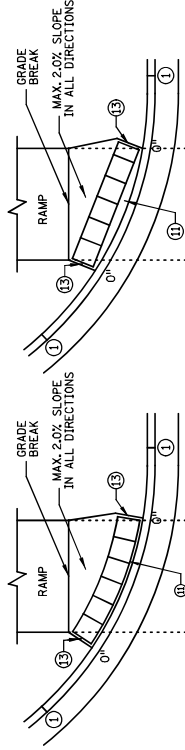

ONE-WAY DIRECTIONAL WITH DETECTABLE WARNING AT BACK OF CURB

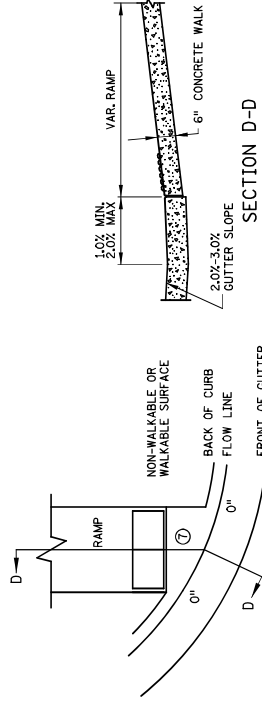

CURB FOR DIRECTIONAL RAMPS

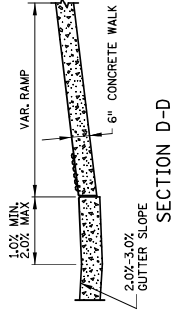

SECTION D-D

NOTES:

1. DOMES SHALL BE LOCATED ANYWHERE THE PEDESTRIAN ACCESS ROUTE (PAR) CHANGES DIRECTION AT THE TOP OF RAMPS THAT HAVE RUNNING SLOPES GREATER THAN 5.0% AND IF THE APPROACHING WALK IS INVERSE GRADE.
2. INITIAL CURB RAMP LANDINGS SHALL BE CONSTRUCTED WITHIN 15' FROM THE BACK APPLICABLE WHEN THE INITIAL RAMP RUNNING SURFACES COVERED DISTANCE, ONLY SECONDARY CURB RAMP LANDINGS ARE REQUIRED FOR EVERY 30' OF VERTICAL RISE WHEN THE LONGITUDINAL SLOPE IS GREATER THAN 5.0%.
3. CONTRACTION JOINTS SHALL BE CONSTRUCTED ALONG ALL GRADE BREAKS WITHIN THE PAR, 1/4" DEEP VISUAL JOINTS SHALL BE USED AT THE TOP GRADE BREAK OF CONCRETE FLARES ADJACENT TO WALKABLE SURFACES. TO ENSURE INITIAL RAMPS AND INITIAL LANDINGS ARE PROPERLY CONSTRUCTED, LANDINGS SHALL BE CAST SEPARATELY, FOLLOW SIDEWALK REINFORCEMENT DETAILS ON SHEET 6 AND THE ADA SPECIAL PROVISION PROSECUTION OF WORK.
4. TOP OF CURB SHALL MATCH PROPOSED ADJACENT WALK GRADE.
5. WHEN THE BOULEVARD IS 4' WIDE OR LESS, THE TOP OF CURB TAPER SHALL MATCH THE RAMP SLOPES TO REDUCE NEGATIVE BOLLEVAARD SLOPES FROM THE TOP BACK OF CURB TO THE PAR.
6. ALL RAMP TYPES SHOULD HAVE A MINIMUM 3'-1" LONG RAMP LENGTH.
7. 4'-MINIMUM WIDTH OF DETECTABLE WARNING IS REQUIRED FOR ALL RAMPS. DETECTABLE WARNINGS SHALL CONTINUOUSLY EXTEND FOR A MIN. OF 24" IN THE PATH OF TRAVEL. DETECTABLE WARNING TO COVER EXCEPTED 3'-MIN. MAXIMUM ON EACH SIDE OF DETECTABLE WARNING WHICH ENSURES THE DETECTABLE WARNINGS ARE ENCASED IN CONCRETE WHEN ADJACENT TO TURF WHEN ADJACENT TO CONCRETE FLARES 0" - 3" OFFSET IS ALLOWED.
8. WHEN DESIGNING OR ORDERING RECTANGULAR DETECTABLE WARNING SURFACES SHOULD BE 6" LESS THAN THE DESIGNING PAR AND LENGTH OF THE RADIAL DETECTABLE WARNINGS SHOULD NOT BE GREATER THAN 20 FEET.
9. RADIAL DETECTABLE WARNINGS SHALL BE SETBACK 3'-MINIMUM TO 6" MAXIMUM FROM THE BACK OF CURB. SEE NOTES 10 & 11 FOR INFORMATION REGARDING RECTANGULAR DETECTABLE WARNING PLACEMENT.
10. 1 MATCH FULL CURB HEIGHT.
11. 3" HIGH CURB WHEN USING A 3' LONG RAMP.
12. 4" HIGH CURB WHEN USING A 4' LONG RAMP.
13. 3' MINIMUM CURB HEIGHT (5' MIN. DISTANCE REQUIRED BETWEEN DOMES)
14. THE "BUMP" IN BETWEEN THE RAMPS SHOULD NOT BE IN THE PATH OF TRAVEL FOR COMBINED DIRECTIONAL RAMPS. IF THIS OCCURS MODIFY THE RAMP LOCATION OR SWITCH RAMP TO A TAN/DEPRESSED CORNER.
15. WHEN USING CONCRETE PAVED FLARES ON THE OUTSIDE OF DIRECTIONAL RAMPS, AND ADJACENT TO A WALKABLE SURFACE, DIRECTIONAL RAMP FLARES SHALL BE USED. SEE THE DETAIL ON THIS SHEET.
16. GRAZING SHALL ALWAYS BE USED WHEN FEASIBLE. V CURB, IF USED, SHALL BE PLACED OUTSIDE THE SIDEWALK SHOULD BE USED OVER V CURB TO REDUCE TRIPPING HAZARDS AND FACILITATE SNOW & ICE REMOVAL.
17. MAX 2.0% SLOPE IN ALL DIRECTIONS IN FRONT OF GRADE BREAK AND DRAIN TO FLOW LINE SHALL BE.
18. CONSTRUCTED INTEGRAL WITH CURB AND GUTTER.
19. 8% TO 10% WALKABLE FLARE.
20. PLACE DOMES AT THE BACK OF CURB WHEN ALLOWABLE SETBACK CRITERIA IS EXCEEDED.
21. FRONT EDGE OF DETECTABLE WARNING SHALL BE SET BACK 2' MAXIMUM WHEN ADJACENT TO WALKABLE SURFACE OF CURB. WALKABLE SURFACES SHALL BE SET BACK 2' FROM THE CORNER TO THE CORNER WITHOUT RAISED OBSTACLES THAT COULD MISTAKENLY BE TRAVERSED BY A USER WHO IS VISUALLY IMPAIRED.
22. RECTANGULAR DETECTABLE WARNINGS MAY BE SETBACK UP TO 9" FROM THE BACK OF CURB WITH CORNERS SET 3" FROM BACK OF CURB. IF 9" SETBACK IS EXCEEDED USE RADIAL DETECTABLE WARNINGS.
23. FOR DIRECTIONAL RAMPS WITH THE DETECTABLE WARNINGS PLACED AT THE BACK OF CURB, THE DETECTABLE WARNINGS SHALL COVER THE ENTIRE WIDTH OF THE WALK PATH. THIS ENSURES A DETECTABLE EDGE AND HELPS ELIMINATE THE CURB TAPER OBSTRUCTING THE PATH OF PEDESTRIAN TRAVEL.
24. THE CONCRETE WALK SHALL BE FORMED AND CONSTRUCTED PERPENDICULAR TO THE BACK OF CURB. MAINTAIN 3" BETWEEN EDGE OF DOMES AND EDGE OF CONCRETE.
25. PLACE 2 NO. 4 BARS 4 INCHES FROM SIDE OF FORMS WITH A MINIMUM 2 INCHES OF CONCRETE COVER ALONG EACH SIDE OF FLARE (INCIDENTAL).

LEGEND

- 1 THESE LONGITUDINAL SLOPE RANGES SHALL BE THE STARTING POINT, IF SITE CONDITIONS WARRANT, LONGITUDINAL SLOPES UP TO 8.3% OR FLATTER ARE ALLOWED.
- 2 INDICATES PEDESTRIAN RAMP - SLOPE SHALL BE BETWEEN 1.0% AND 2.0% WITH THE DIRECTION SHOWN
- 3 AND THE CROSS SLOPE SHALL NOT EXCEED 2.0%.
- 4 INDICATES PEDESTRIAN RAMP - SLOPE SHALL BE GREATER THAN 2.0% AND LESS THAN 5.0% IN THE DIRECTION SHOWN
- 5 AND CROSS SLOPE SHALL NOT EXCEED 2.0%.
- 6 LANDING AREA - 4' X 4' MIN. (5' X 5' MIN. PREFERRED DIMENSIONS AND MAX 2.0% SLOPE IN ALL DIRECTIONS. LANDING SHALL BE FULL WIDTH OF INCOMING PARS.
- 7 CURB HEIGHT

<p>MINNESOTA DEPARTMENT OF TRANSPORTATION</p>	<p>STANDARD PLAN 5-297.250</p>	<p>2 OF 6</p>	<p>PEDESTRIAN CURB RAMP DETAILS</p>
	<p>APPROVED: 11-04-2021</p>	<p>REVISION:</p>	<p>(T.H.) SHEET NO. OF SHEETS</p>
<p>STATE PROJ. NO.</p>		<p>DESIGNED BY: THOMAS E. FISHER</p>	
<p>APPROVED: 11-04-2021</p>		<p>OPERATIONS DIVISION</p>	

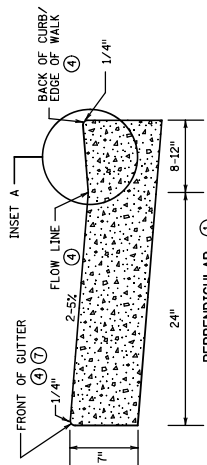
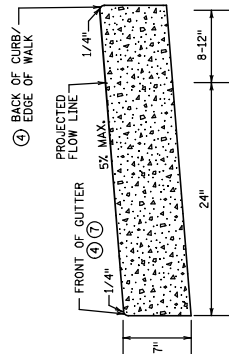
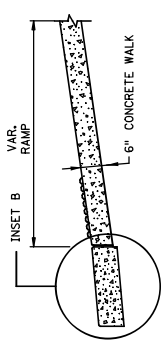

PERPENDICULAR ①

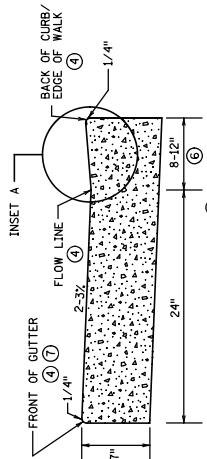

NON PERPENDICULAR ②

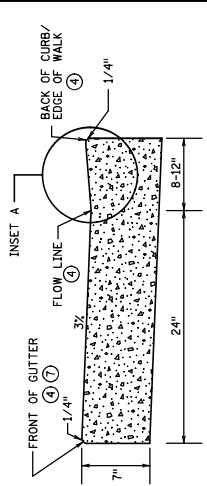

FOR CURB MACHINE PLACEMENT AROUND RADIUS ③
(REGARDLESS OF RAMP TYPE)

PEDESTRIAN ACCESS ROUTE CURB & GUTTER DETAIL

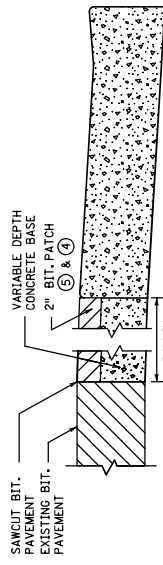
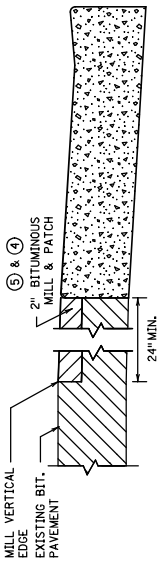
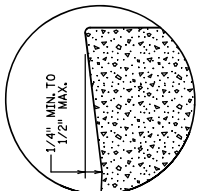

ONLY ALLOWED PER ENGINEER'S APPROVAL

OUTFLOW GUTTER ⑥

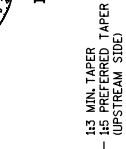

INSET A

INSET B

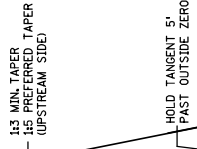

ADA CURB EXTENSION WITH COMPOUND RADIUS (BUMP OUT) ⑧

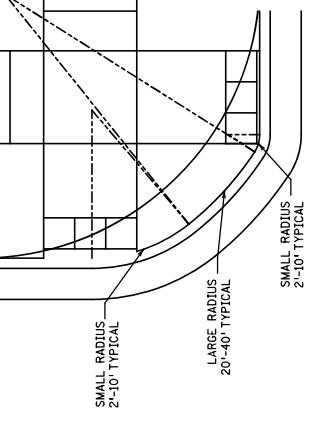

COMBINED DIRECTIONAL (COMPOUND RADIUS) ⑩

PAVEMENT TREATMENT OPTIONS IN FRONT OF CURB & GUTTER

FOR USE ON CURB RAMP RETROFITS

- NOTES:**
- POSITIVE FLOW LINE DRAINAGE SHALL BE MAINTAINED THROUGH THE PEDESTRIAN ACCESS ROUTE (PAR) AT A 2% MAXIMUM. NO PONDING SHALL BE PRESENT IN THE PAR.
 - ANY VERTICAL LIP THAT OCCURS AT THE FLOW LINE SHALL NOT BE GREATER THAN 1/4 INCH.
 - FOR USE AT CURB CUTS WHERE THE PEDESTRIAN PATH OF TRAVEL IS ASSUMED PERPENDICULAR TO THE GUTTER FLOW LINE, RAMP TYPES INCLUDE PERPENDICULAR, TIERED PERPENDICULAR, PARALLEL, AND DIAGONAL RAMP TYPES.
 - FOR USE AT CURB RAMP TYPES WHERE THE PEDESTRIAN PATH OF TRAVEL IS ASSUMED NON PERPENDICULAR TO THE GUTTER FLOW LINE, RAMP TYPES INCLUDE FANS & DEPRESSED CORNERS.
 - BEGIN GUTTER SLOPE TRANSITION 10' OUTSIDE OF ALL CURB RAMP.
 - THERE SHALL BE NO VERTICAL DISCONTINUITIES GREATER THAN 1/4".
 - ELEVATION CHANGE TAKES PLACE FROM THE EXISTING TO NEW FRONT OF GUTTER. PATCH IS USED TO MATCH THE NEW GUTTER FACE INTO THE EXISTING ROADWAY.
 - VARIABLE WIDTH FOR DIRECTIONAL CURB APPLICATIONS. SEE SHEET 2 FOR DIRECTIONAL CURB SLOPE REQUIREMENTS.
 - TOP FRONT OF GUTTER SHALL BE CONSTRUCTED FLUSH WITH PROPOSED ADJACENT PAVEMENT ELEVATION.
 - SHOULD BE USED AT SEGMENTS:
 - ① ELEVATED ROADWAY SEGMENTS;
 - ② CENTER TO CENTER EXISTING CONCRETE PAVEMENT MINIMUM FROM ALL JOINTS
 - HELPS PROVIDE TWO SEPARATE RAMP TYPES, REDUCES THE RAMP LENGTH AND MINIMIZE DIRECTIONAL CURB. THIS RADIUS DESIGN CLOSELY FOLLOWS THE TURNING VEHICLE PATH WHILE OPTIMIZING CURB RAMP LENGTH.
 - CURB EXTENSIONS SHOULD BE USED IN VERTICALLY CONSTRAINED AREAS USUALLY IN DOWNTOWN ROADWAY SEGMENTS WHERE ON-STREET PARKING IS AVAILABLE. CURB EXTENSIONS SHOULD BE CONSIDERED FOR AP5 INTERSECTIONS WHERE SPACE IS LIMITED.
 - PUSH BUTTONS MUST MEET AP5 CRITERIA AS DESCRIBED IN THE PUSH BUTTON LOCATION DETAIL SHEET.

REVISION: APPROVED: 11-04-2021
 [Signature]
 OPERATIONS DIVISION

STANDARD PLAN 5-297.250 3 OF 6
 APPROVED: 11-04-2021
 [Signature]
 THOMAS J. BRIDGES
 STATE DESIGN ENGINEER

MINNESOTA DEPARTMENT OF TRANSPORTATION
 PEDESTRIAN CURB RAMP DETAILS
 (TH) SHEET NO. OF SHEETS

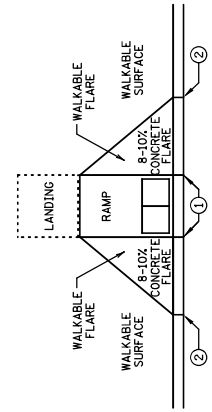

PAVED FLARES ADJACENT TO WALKABLE SURFACE

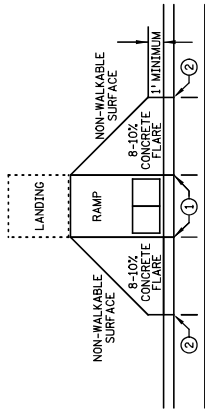

PAVED FLARES ADJACENT TO NON-WALKABLE SURFACE

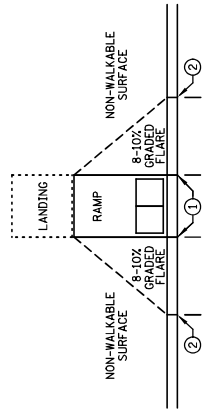

GRADED FLARES

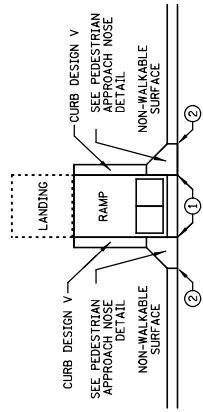

RETURNED CURB ④

TYPICAL SIDE TREATMENT OPTIONS ③ ④

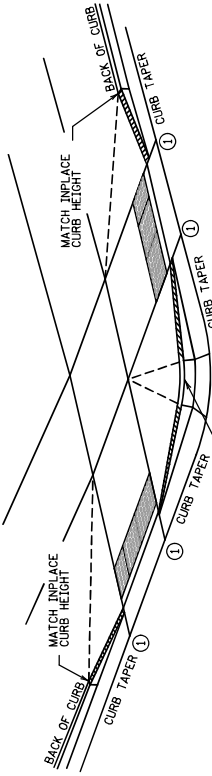

DETECTABLE EDGE WITH CURB AND GUTTER

DETECTABLE EDGE WITH CURB AND GUTTER

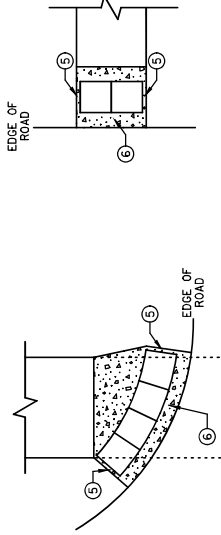

RADIAL DETECTABLE WARNING

RECTANGULAR DETECTABLE WARNING

DETECTABLE EDGE WITHOUT CURB AND GUTTER

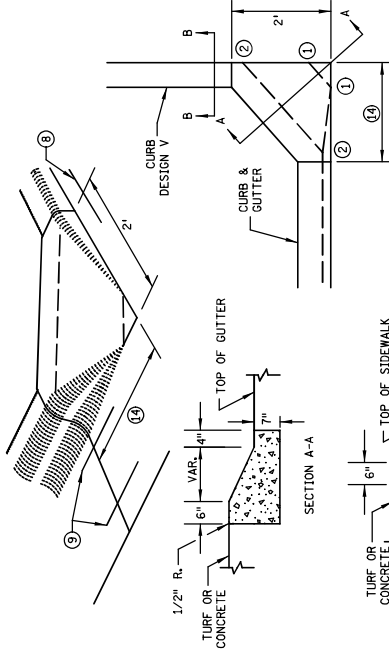

PEDESTRIAN APPROACH NOSE DETAIL (FOR RETURNED CURB SIDE TREATMENT)

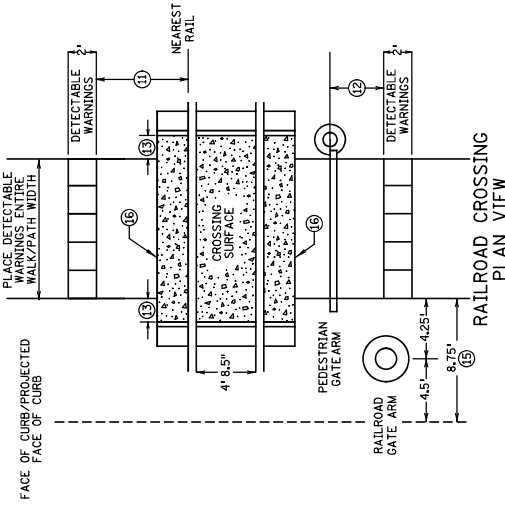

RAILROAD CROSSING PLAN VIEW

NOTES:
 INTERMEDIATE CURB HEIGHTS TAPER SHALL RISE AT 8-10% TO A MINIMUM 3 INCH CURB HEIGHT. INCREASE CURB TAPER LENGTH AT LESS THAN 8% OR REDUCE INTERMEDIATE CURB HEIGHT TO 2+ INCHES IF NECESSARY TO MATCH ADJACENT BOULEVARD OR SIDEWALK GRADES.
 SEE STANDARD PRACTICE 7038 AND THIS SHEET FOR ADDITIONAL DETAILS ON DETECTABLE WARNING.
 A WALKABLE SURFACE IS DEFINED AS A PAVED SURFACE ADJACENT TO A CURB RAMP WITHOUT CONCRETE FLARE LENGTHS ADJACENT TO NON-WALKABLE SURFACES SHOULD BE LESS THAN 8' LONG MEASURED ALONG THE RAMP FROM THE BACK OF CURB.
 ① 0" CURB HEIGHT. SEE INSET A ON SHEET 3 OF 6.
 ② FULL CURB HEIGHT.
 ③ SIDE TREATMENTS ARE APPLICABLE TO ALL RAMP TYPES AND SHOULD BE IMPLEMENTED AS NEEDED AS FIELD CONDITIONS PERMIT. THIS INCLUDES RAMP TYPES WITH MEDIAN, SIDEWALK, ADJACENT PROPERTY CONSIDERATIONS, AND MITIGATING CONSTRUCTION IMPACTS.
 ④ TYPICALLY USED FOR MEDIANS AND ISLANDS.
 ⑤ WHEN NO CONCRETE FLARES ARE PROPOSED, THE CONCRETE WALK SHALL BE FORMED AND CONSTRUCTED PERPENDICULAR TO THE EDGE OF ROADWAY. MAINTAIN 3" MAX. BETWEEN EDGE OF DOWNS AND EDGE OF CONCRETE.
 ⑥ IF NO CURB AND GUTTER IS PLACED IN RURAL SECTIONS, DETECTABLE WARNINGS SHALL BE PLACED 1' FROM THE EDGE OF BITUMINOUS ROADWAY AND/OR BITUMINOUS SHARED-USE PATH TO PROVIDE VISUAL CONTRAST.
 ⑦ ALL CONSTRUCTED CURBS MUST HAVE A CONTINUOUS DETECTABLE EDGE FOR THE VISUALLY IMPAIRED. THIS DETECTABLE EDGE REQUIRES DETECTABLE WARNINGS WHEREVER THERE IS ZERO-INCH HIGH CURB. CURB TREATMENTS ARE CONSIDERED A DETECTABLE EDGE WHERE THE CURB HEIGHT IS LESS THAN 3 INCHES. CURB TREATMENTS ARE NOT CONSIDERED A DETECTABLE EDGE AND THEREFORE IS NOT COMPLIANT WITH ACCESSIBILITY STANDARDS.
 ⑧ DRILL AND GROUT 1 - NO. 4 1/2" LONG REINFORCEMENT BAR (EPOXY COATED) WITH 3" MIN. COVER. REINFORCEMENT BARS ARE NOT NEEDED IF THE APPROACH NOSE IS POURED INTEGRAL WITH THE V CURB.
 ⑨ DRILL AND GROUT 2 - NO. 4 1/2" LONG REINFORCEMENT BARS (EPOXY COATED) WITH 3" MIN. COVER. REINFORCEMENT BARS ARE NOT NEEDED IF THE APPROACH NOSE IS POURED INTEGRAL WITH THE CURB AND GUTTER.
 ⑩ SIDE TREATMENT EXAMPLES SHOWN ARE WHEN THE INITIAL LANDING IS APPROXIMATELY LEVEL WITH THE FULL HEIGHT CURB REFER TO (C.E. 6) LONG RAMP FOR 6" HIGH CURB. WHEN THE INITIAL LANDING IS MORE THAN 1" BELOW FULL HEIGHT CURB REFER TO TREATMENT 1 & 2. MODIFY THE CURB HEIGHT TO 6" MINIMUM TO PROVIDE POSITIVE DRAINAGE. CONSTRUCT THESE TREATMENTS AT 0'-3" AT 8-10%, THEN LESS THAN 8% FROM 3' CURB TO FULL CURB HEIGHT.
 ⑪ NEAREST EDGE OF DETECTABLE WARNING SURFACES SHALL BE PLACED 12" MINIMUM TO 15" MAXIMUM FROM THE NEAREST RAMP AS MEASURED TO THE NEAREST RAIL.
 ⑫ WHEN PEDESTRIAN GATES ARE PROVIDED, DETECTABLE WARNINGS SURFACES SHALL BE PLACED ON THE SIDE OF THE GATES OPPOSITE THE RAIL 2' FROM THE APPROACHING SIDE OF THE GATE ARM. THIS CRITERIA GOVERNS OVER NOTE ⑪.
 ⑬ CROSSING SURFACE SHALL EXTEND 2' MINIMUM PAST THE OUTSIDE EDGE OF WALK ON SHARED-USE PATH.
 ⑭ 3" FOR MEDIANS AND SPLITTER ISLANDS. NOSE CAN BE REDUCED TO 2" ON FREE RIGHT ISLANDS.
 ⑮ SIDEWALK TO BE PLACED 8.75' MIN. FROM THE FACE OF CURB/PROJECTED FACE OF CURB. THIS ENSURES MIN. CLEARANCE BETWEEN THE SIDEWALK AND GATE ARM COUNTERWEIGHT SUPPORTS.
 ⑯ CONSTRUCT WITH EXPANSION MATERIAL PER MNDOT SPECIFICATION 3702 TYPES A-E.
 ⑰ EXPANSION MATERIAL SHALL MATCH FULL HEIGHT OF ADJACENT CONCRETE.

REVISION: APPROVED: 11-04-2021
 THOMAS J. FISHER
 STATE DESIGN ENGINEER

STANDARD PLAN 5-297.250 4 OF 6
 APPROVED: 11-04-2021
 THOMAS J. FISHER
 STATE DESIGN ENGINEER



PEDESTRIAN CURB RAMP DETAILS
 (T H) SHEET NO. OF SHEETS

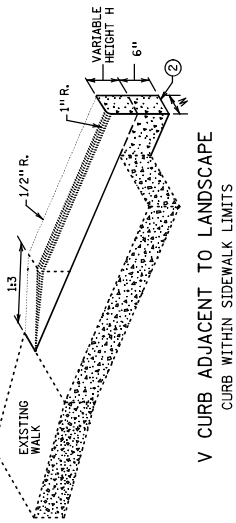

V CURB ADJACENT TO LANDSCAPE
CURB WITHIN SIDEWALK LIMITS

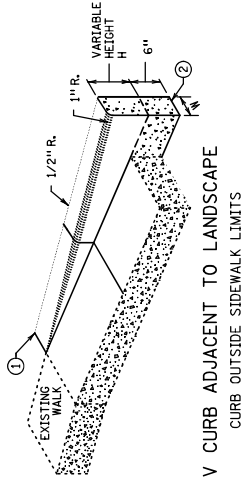

V CURB ADJACENT TO LANDSCAPE
CURB OUTSIDE SIDEWALK LIMITS

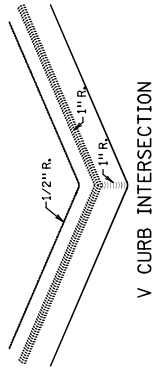

V CURB INTERSECTION

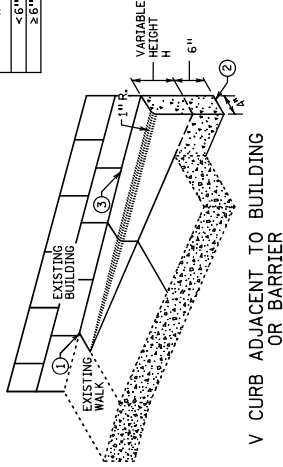

V CURB ADJACENT TO BUILDING
OR BARRIER

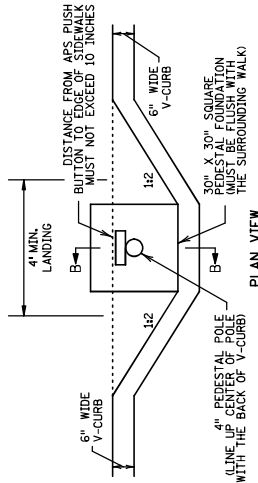

SECTION B-B
SIGNAL PEDESTAL & PUSH BUTTON (V-CURB)

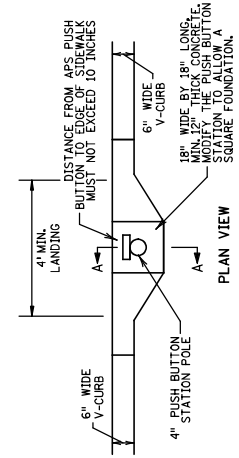

SECTION A-A
PUSH BUTTON STATION (V-CURB)

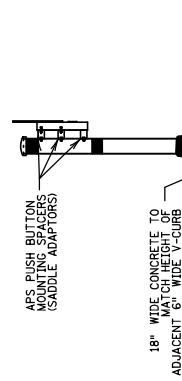

CONCRETE CURB DESIGN V	
CURB HEIGHT H	CURB WIDTH W
<6"	4"
≥6"	6"

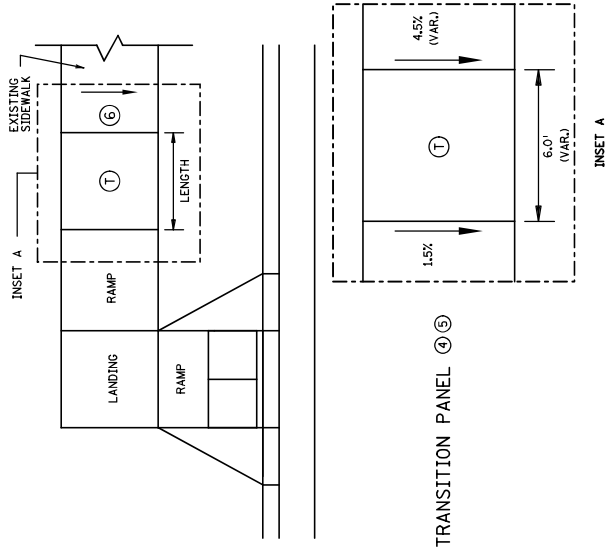

TRANSITION PANEL ⑤

NOTES:

- WALKABLE FLARE IS AN 8.0% CONCRETE FLARE THAT IS REQUIRED WHEN THE FLARE IS ADJACENT TO A WALKABLE SURFACE OR WHEN THE PEDESTRIAN PATH OF TRAVEL OF A PUSH BUTTON TRAVERSES THE FLARE.
- ALL V CURB CONTRACTION JOINTS SHALL MATCH CONCRETE WALK JOINTS.
- WHERE RIGHT-OF-WAY ALLOWS, USE OF V CURB SHOULD BE MINIMIZED. GRADING ADJACENT TO V CURB SHOULD BE MINIMIZED. GRADING ADJACENT TO V CURB SHOULD BE PLACED OUTSIDE THE SIDEWALK LIMITS WHEN RIGHT OF WAY ALLOWS.
- V CURB NEXT TO BUILDING SHALL BE A 4" WIDTH AND SHALL MATCH PREVIOUS TOP OF SIDEWALK ELEVATIONS.
- END TAPERS AT TRANSITION SECTION SHALL MATCH INPLACE SIDEWALK GRADES.
- ALL V CURB SHALL MATCH BOTTOM OF ADJACENT WALK.
- CONSTRUCT USING APPROVED EXPANSION MATERIAL PER MNDOT TYPE A-E EXPANSION. LEAVE A MINIMUM 1/2" TOP GAP AND SEAL WITH MNDOT APPROVED SILICONE PER MNDOT SPEC 3722.
- THE MAX. RATE OF CROSS SLOPE TRANSITIONING IS 1" LINEAR FOOT OF SIDEWALK PER HALF PERCENT CROSS SLOPE. WHEN PAR WIDTH IS GREATER THAN 6' OR THE RUNNING SLOPE IS GREATER THAN 5%, DOUBLE THE CALCULATED TRANSITION LENGTH.
- TRANSITION PANELS ARE TO ONLY BE USED AFTER THE RAMP, OR IF NEEDED, LANDING ARE AT THE FULL CURB HEIGHT (TYPICAL SECTION).
- EXISTING CROSS SLOPE GREATER THAN 2.0%.

LEGEND

- THESE LONGITUDINAL SLOPE RANGES SHALL BE THE STARTING POINT IF SITE CONDITIONS WARRANT. LONGITUDINAL SLOPES UP TO 8.3% OR FLATTER ARE ALLOWED.
- INDICATES PEDESTRIAN RAMP - SLOPE SHALL BE BETWEEN 5.0% MINIMUM AND 8.3% MAXIMUM IN THE DIRECTION SHOWN AND THE CROSS SLOPE SHALL NOT EXCEED 2.0%.
 - LANDING AREA - 4' X 4' MIN. (5' X 5' MIN. PREFERRED) DIMENSIONS AND MAX 2.0% SLOPE IN ALL DIRECTIONS. LANDING SHALL BE FULL WIDTH OF INCOMING PARS.
 - TRANSITION PANEL(S) - TO BE USED FOR TRANSITIONING THE CROSS-SLOPE OF A RAMP TO THE EXISTING WALK CROSS-SLOPE. RATE OF TRANSITION SHOULD BE 0.5% PER 1 LINEAR FOOT OF WALK. SEE THIS SHEET FOR ADDITIONAL INFORMATION.

STANDARD PLAN 5-297.250 5 OF 6

APPROVED: 11-04-2021

REVISIONS:

APPROVED: 11-04-2021

OPERATIONS DIVISION

MINNESOTA DEPARTMENT OF TRANSPORTATION

THOMAS F. FISHER STATE DESIGN ENGINEER

STATE PROJ. NO. (TH) SHEET NO. OF SHEETS

PEDESTRIAN CURB RAMP DETAILS

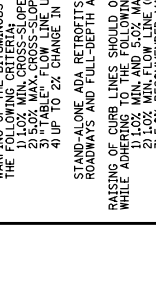
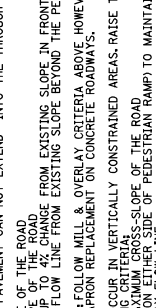
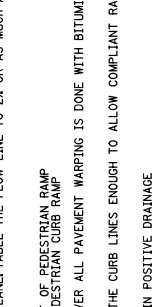
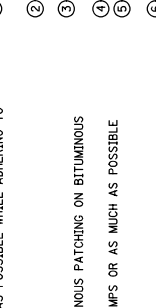
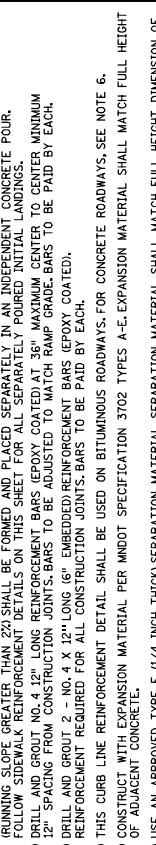
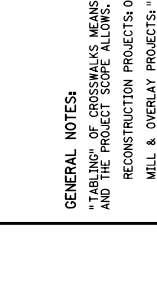
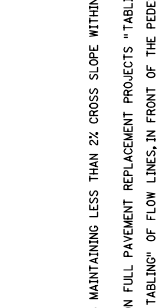
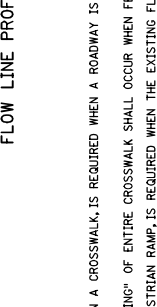
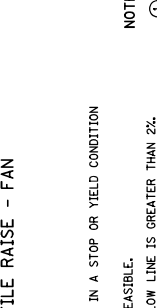
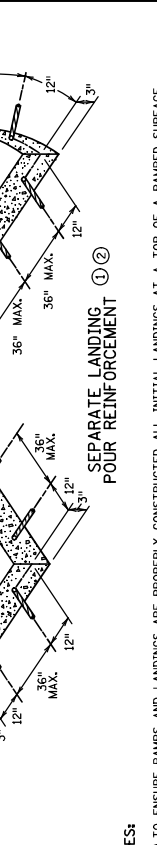
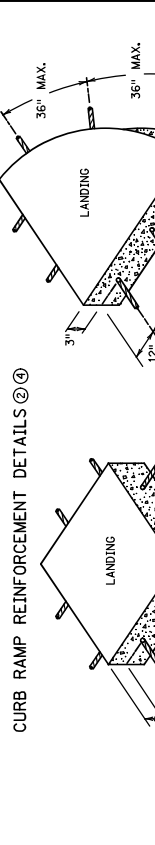
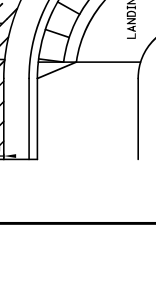
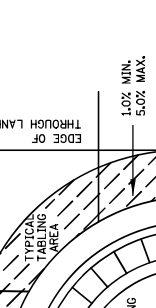
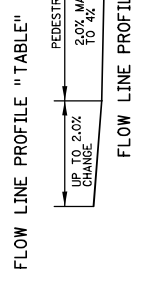
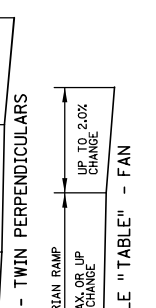
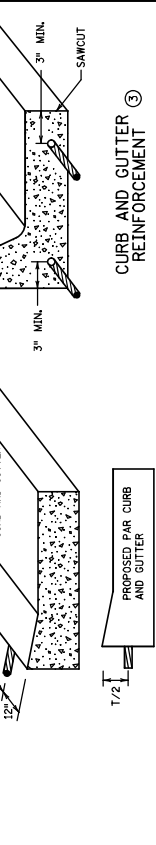
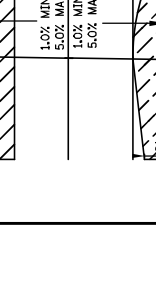
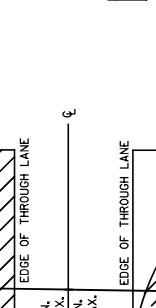
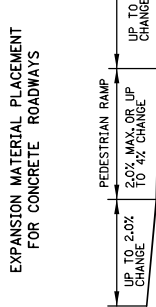
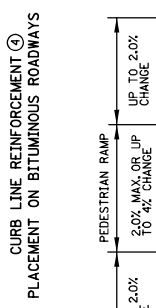
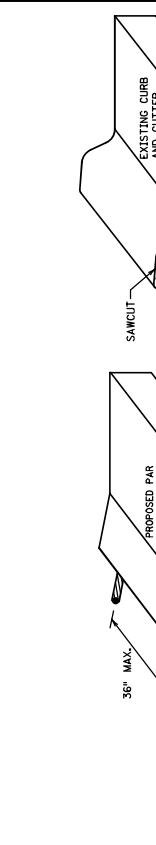
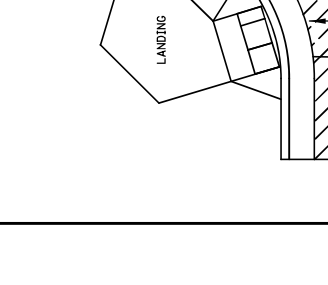
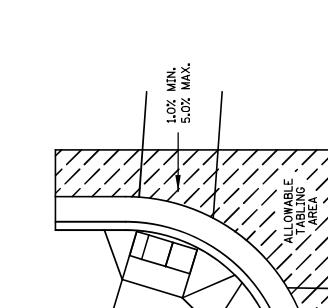
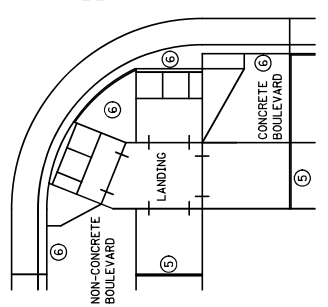
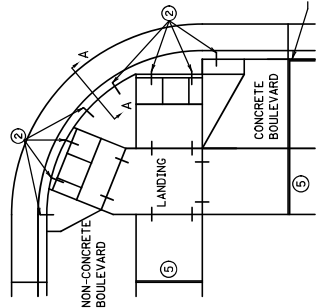
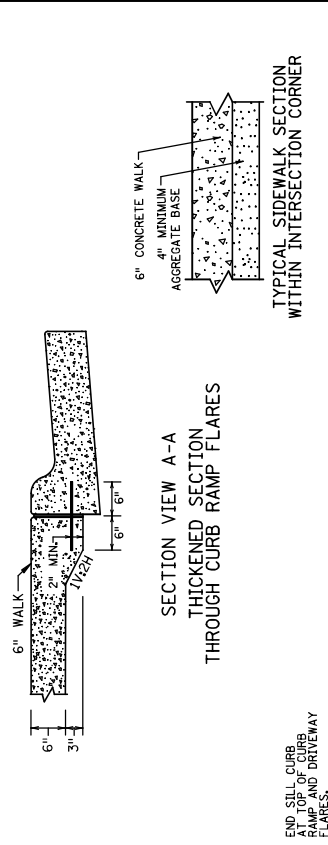

STANDARD PLAN 5-297.250 6 OF 6

APPROVED: 11-04-2021

REVISION: 11-04-2021

THOMAS J. FISCHER
STATE DESIGN ENGINEER

STATE PROJ. NO. () SHEET NO. OF SHEETS

PEDESTRIAN CURB RAMP DETAILS

MINNESOTA DEPARTMENT OF TRANSPORTATION

OPERATIONS DIVISION

APPROVED: 11-04-2021

THOMAS J. FISCHER
STATE DESIGN ENGINEER

STATE PROJ. NO. () SHEET NO. OF SHEETS

PEDESTRIAN CURB RAMP DETAILS

Attachment B:

ADA Curb Ramp Checklist

City of Minneapolis: Public Works

ROW Management

2023

ADA Curb Ramp Compliance Checklist

Permit Information									
Permit #:			Contractor:						
Project Owner:									
Ramp Location									
Street 1:					Street 2:				
Quadrant:					Infrastructure Type:				
Ramp Detail									
Ramp Type:					Construction Year:				
Is a 4' wide minimum pedestrian access route (PAR) maintained?						<input type="radio"/> Yes		<input type="radio"/> No	
Does landing meet 4'X 4' minimum and perpendicular grade breaks?						<input type="radio"/> Yes		<input type="radio"/> No	
Are landings located at the top of each ramp, changes in direction and at inverse grades?						<input type="radio"/> Yes		<input type="radio"/> No	
Landing slopes (%): <i>* > 2% is non-compliant</i>		Initial Secondary		Street 1		Initial Secondary		Street 2	
Ramp running slope (%): <i>* > 8.3% is non-compliant</i>		<input type="text"/>		<input type="text"/>		<input type="text"/>		<input type="text"/>	
Ramp cross slope (%): <i>* > 2% is non-compliant</i>		<input type="text"/>		<input type="text"/>		<input type="text"/>		<input type="text"/>	
Gutter flow line slope (%): <i>* > 2% is non-compliant</i>		<input type="text"/>		<input type="text"/>		<input type="text"/>		<input type="text"/>	
Gutter inslope (%): <i>* > 5% is non-compliant:</i>		<input type="text"/>		<input type="text"/>		<input type="text"/>		<input type="text"/>	
Roadway cross slope (%): <i>* > 5% is non-compliant</i>		<input type="text"/>		<input type="text"/>		<input type="text"/>		<input type="text"/>	
Do truncated domes cover the entire curb openings and are they properly oriented?						<input type="radio"/> Yes		<input type="radio"/> No	
Are gutter line and ramps draining properly?						<input type="radio"/> Yes		<input type="radio"/> No	
Are there any vertical discontinuities greater than 1/4"?						<input type="radio"/> Yes		<input type="radio"/> No	
Do ramps comply with MnDOT Spec. 2521.3?						<input type="radio"/> Yes		<input type="radio"/> No	
Are ramps fully compliant?						<input type="radio"/> Yes		<input type="radio"/> No	
If no, check why: <input type="checkbox"/> Topography <input type="checkbox"/> Structures <input type="checkbox"/> Utilities <input type="checkbox"/> Contractor <input type="checkbox"/> Tree <input type="checkbox"/> City									
Explain why the ramp didn't meet compliance and how the ramp has been improved from the pre-construction condition. (See MnDOT ADA Compliance Checklist Guidance[Curb Ramps] for more information and attach pages if needed.)									
Was the curb ramp able to be built to the plan details? (If no custom plan, refer to MnDOT Standard Plans.)						<input type="radio"/> Yes		<input type="radio"/> No	
If no, please explain:									
CERTIFICATION STATEMENT									
<input type="checkbox"/> By checking this box, I certify all information entered on this form is true and accurate to the best of my knowledge and that I fully understand the checklist standards and I am qualified to carry out the inspection.									
Printed Name:						Date:			

Attachment C:

Department of Justice / Department of Transportation Joint Technical Assistance

**on the Title II of the Americans with Disabilities Act
Requirements To Provide Curb Ramps when Streets, Roads,
or Highways are Altered through Resurfacing**

City of Minneapolis: Public Works

ROW Management

2023



U.S. Department of Justice
Civil Rights Division
Disability Rights Section



U.S. Department of Transportation
Federal Highway Administration

Department of Justice/Department of Transportation Joint Technical Assistance¹ on the Title II of the Americans with Disabilities Act Requirements to Provide Curb Ramps when Streets, Roads, or Highways are Altered through Resurfacing

Title II of the Americans with Disabilities Act (ADA) requires that state and local governments ensure that persons with disabilities have access to the pedestrian routes in the public right of way. An important part of this requirement is the obligation whenever streets, roadways, or highways are *altered* to provide curb ramps where street level pedestrian walkways cross curbs.² This requirement is intended to ensure the accessibility and usability of the pedestrian walkway for persons with disabilities.

An alteration is a change that affects or could affect the usability of all or part of a building or facility.³ Alterations of streets, roads, or highways include activities such as reconstruction, rehabilitation, *resurfacing*, widening, and projects of similar scale and effect.⁴ Maintenance activities on streets, roads, or highways, such as filling potholes, are not alterations.

Without curb ramps, sidewalk travel in urban areas can be dangerous, difficult, or even impossible for people who use wheelchairs, scooters, and other mobility devices. Curb ramps allow people with mobility disabilities to gain access to the sidewalks and to pass through center islands in streets. Otherwise, these individuals are forced to travel in streets and roadways and are put in danger or are prevented from reaching their destination; some people with disabilities may simply choose not to take this risk and will not venture out of their homes or communities.

Because resurfacing of streets constitutes an alteration under the ADA, it triggers the obligation to provide curb ramps where pedestrian walkways intersect the resurfaced streets. See *Kinney v. Yerusalim*, 9 F 3d 1067 (3rd Cir. 1993). This obligation has been discussed in a variety of technical assistance materials published by the Department of Justice beginning in 1994.⁵ Over the past few years, state and local governments have sought further guidance on the scope of the alterations requirement with respect to the provision of curb ramps when streets, roads or highways are being resurfaced. These questions have arisen largely due to the development of a variety of road surface treatments other than traditional road resurfacing, which generally involved the addition of a new layer of asphalt. Public entities have asked the Department of Transportation and the Department of Justice to clarify whether particular road surface treatments fall within the ADA definition of alterations, or whether they should be considered maintenance that would not trigger the obligation to provide curb ramps. This Joint Technical Assistance addresses some of those questions.

Where must curb ramps be provided?

Generally, curb ramps are needed wherever a sidewalk or other pedestrian walkway crosses a curb. Curb ramps must be located to ensure a person with a mobility disability can travel from a sidewalk on one side of the street, over or through any curbs or traffic islands, to the sidewalk on the other side of the street. However, the ADA does not require installation of ramps or curb ramps in the absence of a pedestrian walkway with a prepared surface for pedestrian use. Nor are curb ramps required in the absence of a curb, elevation, or other barrier between the street and the walkway.

When is resurfacing considered to be an alteration?

Resurfacing is an alteration that triggers the requirement to add curb ramps if it involves work on a street or roadway spanning from one intersection to another, and includes overlays of additional material to the road surface, with or without milling. Examples include, but are not limited to the following treatments or their equivalents: addition of a new layer of asphalt, reconstruction, concrete pavement rehabilitation and reconstruction, open-graded surface course, micro-surfacing and thin lift overlays, cape seals, and in-place asphalt recycling.

What kinds of treatments constitute maintenance rather than an alteration?

Treatments that serve solely to seal and protect the road surface, improve friction, and control splash and spray are considered to be maintenance because they do not significantly affect the public's access to or usability of the road. Some examples of the types of treatments that would normally be considered maintenance are: painting or striping lanes, crack filling and sealing, surface sealing, chip seals, slurry seals, fog seals, scrub sealing, joint crack seals, joint repairs, dowel bar retrofit, spot high-friction treatments, diamond grinding, and pavement patching. In some cases, the combination of several maintenance treatments occurring at or near the same time may qualify as an alteration and would trigger the obligation to provide curb ramps.

What if a locality is not resurfacing an entire block, but is resurfacing a crosswalk by itself?

Crosswalks constitute distinct elements of the right-of-way intended to facilitate pedestrian traffic. Regardless of whether there is curb-to-curb resurfacing of the street or roadway in general, resurfacing of a crosswalk also requires the provision of curb ramps at that crosswalk.

¹ The Department of Justice is the federal agency with responsibility for issuing regulations implementing the requirements of title II of the ADA and for coordinating federal agency compliance activities with respect to those requirements. Title II applies to the programs and activities of state and local governmental entities. The Department of Justice and the Department of Transportation share responsibility for enforcing the requirements of title II of the ADA with respect to the public right of way, including streets, roads, and highways.

² See 28 CFR 35.151(i)(1) (Newly constructed or altered streets, roads, and highways must contain curb ramps or other sloped areas at any intersection having curbs or other barriers to entry from a street level pedestrian walkway) and 35.151(i)(2) (Newly constructed or altered street level pedestrian walkways must contain curb ramps or other sloped areas at intersections to streets, roads, or highways).

³ 28 CFR 35.151(b)(1).

⁴ 2010 ADA Accessibility Standards, section 106.5.

⁵ See 1994 Title II Technical Assistance Manual Supplement, Title II TA Guidance: The ADA and City Governments: Common Problems; and ADA Best Practices Tool Kit for State and Local Governments: Chapter 6, Curb Ramps and Pedestrian Crossings under Title II of the ADA, available at archive.ADA.gov.

The Americans with Disabilities Act authorizes the Department of Justice (the Department) to provide technical assistance to individuals and entities that have rights or responsibilities under the Act. This document provides informal guidance to assist you in understanding the ADA and the Department's regulations.

This guidance document is not intended to be a final agency action, has no legally binding effect, and may be rescinded or modified in the Department's complete discretion, in accordance with applicable laws. The Department's guidance documents, including this guidance, do not establish legally enforceable responsibilities beyond what is required by the terms of the applicable statutes, regulations, or binding judicial precedent.

July 8, 2013



U.S. Department of Justice
Civil Rights Division
Disability Rights Section



U.S. Department of Transportation
Federal Highway Administration

QUESTIONS & ANSWERS

Supplement to the 2013 DOJ/DOT Joint Technical Assistance on the Title II of the Americans with Disabilities Act Requirements To Provide Curb Ramps when Streets, Roads, or Highways are Altered through Resurfacing

The *Department of Justice (DOJ)/Department of Transportation (DOT) [Joint Technical Assistance on the Title II of the Americans with Disabilities Act \[ADA\] Requirements to Provide Curb Ramps when Streets, Roads, or Highways are Altered through Resurfacing](#)* (*Joint Technical Assistance*) was published on July 8, 2013. This document responds to frequently asked questions that the Federal Highway Administration (FHWA) has received since the technical assistance document was published. In order to fully address some questions, the applicable requirements of Section 504 of the Rehabilitation Act of 1973 that apply to public entities receiving Federal funding from DOT, either directly or indirectly, are also discussed. This document is not a standalone document and should be read in conjunction with the [2013 Joint Technical Assistance](#).

Q1: *When a pavement treatment is considered an alteration under the ADA and there is a curb ramp at the juncture of the altered road and an existing sidewalk (or other prepared surface for pedestrian use), but the curb ramp does not meet the current ADA Standards, does the curb ramp have to be updated to meet the current ADA Standards at the time of the pavement treatment?*

A1: It depends on whether the existing curb ramp meets the appropriate accessibility standard that was in place at the time it was newly constructed or last altered.

When the Department of Justice adopted its revised title II ADA Regulations including the updated ADA Standards for Accessible Design (2010 Standards,¹ as defined in 28 CFR 35.151), it specified that “(e)lements that have not been altered in existing facilities on or after March 15, 2012, and that comply with the corresponding technical and scoping specifications for those elements in either the 1991 Standards or in the Uniform Federal Accessibility Standards (UFAS) ... are not required to be modified in order to comply with the requirements set forth in the 2010 Standards.” 28 C.F.R. 35.150(b)(2)(i). As a result of this “safe harbor” provision, if a curb ramp was built or altered prior to March 15, 2012, and complies with the requirements for curb ramps in either the 1991 ADA Standards for Accessible Design (1991 Standards, known prior to 2010 as the 1991 ADA Accessibility Guidelines, or the 1991 ADAAG) or UFAS, it does **not** have to be modified to comply with the requirements in the 2010 Standards. However, if that existing curb ramp did not comply with either the 1991 Standards or UFAS as of March 15, 2012, then the safe harbor does not apply and the curb ramp must be brought into compliance with the requirements of the 2010 Standards concurrent with the road alteration. See 28 CFR 35.151(c) and (i).

Note that the requirement in the 1991 Standards to include detectable warnings on curb ramps was suspended for a period between May 12, 1994, and July 26, 1998, and again between December 23, 1998, and July 26, 2001. If a curb ramp was newly constructed or was last altered when the detectable warnings requirement was suspended, and it otherwise meets the 1991 Standards, Title II of the ADA does not require that the curb ramp be modified to add detectable warnings in conjunction with a road resurfacing alteration project. See Question #14 however, for a discussion of the DOT Section 504 requirements, including detectable warnings.

Q2: *The Joint Technical Assistance states that “[r]esurfacing is an alteration that triggers the requirement to add curb ramps if it involves work on a street or roadway spanning from one intersection to another, and includes overlays of additional material to the road surface, with or without milling.” What constitutes “overlays of additional material to the road surface” with respect to milling, specifically, when a roadway surface is milled and then overlaid at the same height (i.e., no material is added that exceeds the height of what was present before the milling)?*

A2: A project that involves milling an existing road, and then overlaying the road with material, regardless of whether it exceeds the height of the road before milling, falls within the definition of “alteration” because it is a change to the road surface that affects or could affect the usability of the pedestrian route (crosswalk). See *Kinney v. Yerusalim*, 9 F.3d 1067 (3rd Cir. 1993). Alterations require the installation of curb ramps if none previously existed, or upgrading of non-compliant curb ramps to meet the applicable standards, where there is an existing pedestrian walkway. See also Question 8.

Q3: *If a roadway resurfacing alteration project does not span the full width of the road, do I have to put in curb ramps?*

A3: It depends on whether the resurfacing work affects a pedestrian crosswalk. If the resurfacing affects the crosswalk, even if it is not the full roadway width, then curb ramps must be provided at both ends of the crosswalk. See 28 CFR 35.151(i).

Public entities should not structure the scope of work to avoid ADA obligations to provide curb ramps when resurfacing a roadway. For example, resurfacing only between crosswalks may be regarded as an attempt to circumvent a public entity’s obligation under the ADA, and potentially could result in legal challenges.

If curb ramp improvements are needed in the vicinity of an alteration project, it is often cost effective to address such needs as part of the alteration project, thereby advancing the public entity’s progress in meeting its obligation to provide program access to its facilities. See Question 16 for further discussion.

Q4: *When a road alteration project triggers the requirement to install curb ramps, what steps should public (State or local) entities take if they do not own the sidewalk right-of-way needed to install the required curb ramps?*

A4: The public entity performing the alteration is ultimately responsible for following and implementing the ADA requirements specified in the regulations implementing title II. At the time an alteration project is scoped, the public entity should identify what ADA requirements apply and whether the public entity owns sufficient right-of-way to make the necessary ADA modifications. If the public entity does not control sufficient

right-of-way, it should seek to acquire the necessary right-of-way. If a complaint is filed, the public entity will likely need to show that it made reasonable efforts to obtain access to the necessary right-of-way.

Q5: *The Joint Technical Assistance is silent on when it becomes effective. Is there an effective date for when States and local public entities must comply with the requirements discussed in the technical assistance?*

A5: The Joint Technical Assistance, as well as this Supplement to it, does not create any new obligations. The obligation to provide curb ramps when roads are altered has been an ongoing obligation under the regulations implementing title II of the ADA (28 CFR 35.151) since the regulation was initially adopted in 1991. This technical assistance was provided to respond to questions that arose largely due to the development of a variety of road surface treatments, other than traditional road resurfacing, which generally involved the addition of a new layer of asphalt. Although the Joint Technical Assistance was issued on July 8, 2013, public entities have had an ongoing obligation to comply with the alterations requirements of title II and should plan to bring curb ramps that are or were part of an alteration into compliance as soon as possible.

Q6: *Is the curb ramp installation work required to be a part of the Plans, Specifications and Estimate package for an alteration project or can the curb ramp work be accomplished under a separate contract?*

A6: The curb ramp installation work can be contracted separately, but the work must be coordinated such that the curb ramp work is completed prior to, or at the same time as, the completion of the rest of the alteration work. See 28 CFR 35.151(i).

Q7: *Is a curb ramp required for a sidewalk that is not made of concrete or asphalt?*

A7: The Joint Technical Assistance states that “the ADA does not require installation of ramps or curb ramps in the absence of a pedestrian walkway with a prepared surface for pedestrian use.” A “prepared surface for pedestrian use” can be constructed out of numerous materials, including concrete, asphalt, compacted soil, decomposed granite, and other materials. Regardless of the materials used to construct the pedestrian walkway, if the intent of the design was to provide access to pedestrians, then curb ramps must be incorporated where an altered roadway intersects the pedestrian walkway. See 28 CFR 35.151(i).

Q8: *If an existing curb ramp is replaced as part of a resurfacing alteration, is there an obligation to address existing obstacles on the adjacent sidewalk at the same time?*

A8: No. The Joint Technical Assistance addresses those requirements that are triggered when a public entity alters a roadway where the roadway intersects a street level pedestrian walkway (28 CFR 35.151(i)). Public entities are required to address other barriers on existing sidewalks, such as steep cross slopes or obstructions, as part of their on-going program access and transition plan obligations under title II of the ADA and Section 504 and in response to requests for reasonable modifications under the ADA or reasonable accommodations under Section 504. See 28 CFR 35.105, 35.130(b)(7), and 35.150(d); see also 49 CFR 27.7(e), 27.11(c)(2).

Q9: *Several pavement preservation treatment types are not listed in the technical assistance. If the treatment type is not specifically on the list of maintenance treatments, is it an alteration?*

A9: New treatments are always being developed and the best practice is for the City or other local public entity conducting the work, the State transportation agency, and FHWA to work together to come to an agreement on a reasonable determination of whether the unlisted treatment type is an alteration or maintenance and document their decisions. If the new treatment can be deemed to be the equivalent of any of the items listed as alterations, it is a reasonable interpretation that they are in fact alterations and should be treated as such.

Q10: *When does a combination of two or more ‘maintenance’ treatments rise to the level of being an alteration?*

A10: The list of the pavement types that are considered maintenance, as stated in the 2013 Joint Technical Assistance document, are Chip Seals, Crack Filling and Sealing, Diamond Grinding, Dowel Bar Retrofit, Fog Seals, Joint Crack Seals, Joint Repairs, Pavement Patching, Scrub Sealing, Slurry Seals, Spot High-Friction Treatments, and Surface Sealing. The combination of two or more maintenance treatments may rise to the level of being an alteration.

The best practice is for the City or other local public entity conducting the work, the State transportation agency, and FHWA to work together to come to an agreement on a reasonable determination, document their policies, and apply that determination consistently in their locality.

Q11: *When will utility trench work require compliance with ADA curb ramp requirements?*

A11: The answer to this question depends on the scope and location of the utility trench work being done. If the utility trench work is limited to a portion of the pavement, even including a portion of the crosswalk, repaving necessary to cover the trench would typically be considered maintenance and would not require simultaneous installation or upgrading of curb ramps. Public entities should note that the ADA requires maintenance of accessible features, and as such, they must ensure that when the trench is repaved or other road maintenance is performed, the work does not result in a lesser level of accessibility. See 28 CFR 35.133(a). If the utility work impacts the curb at a pedestrian street crossing where no curb ramp exists, the work affecting the curb falls within the definition of “alteration,” and a curb ramp must be constructed rather than simply replacing the curb. See 28 CFR 35.151(b) and 35.151(i).

If a public entity is unsure whether the scope of specific trench work and repair/repaving constitutes an alteration, the best practice is for the public entity to work together with the State transportation agency and the FHWA Division to come to an agreement on how to consistently handle these situations and document their decisions.

Q12: *Is full-depth pavement patching considered maintenance?*

A12: The answer to this question depends on the scope and location of the pavement patch. If the pavement patch work is limited to a portion of the pavement, even including a portion of the crosswalk, patching the pavement would typically be considered maintenance and would not require simultaneous installation or upgrading of curb ramps. Public entities should note that the ADA requires maintenance of accessible features, and as such, they should ensure that when the pavement is patched or other road maintenance is performed, the work does not result in a lesser level of accessibility. See 28 CFR 35.133(a). If the pavement

patching impacts the curb at a pedestrian street crossing where no curb ramp exists, the work affecting the curb falls within the definition of “alteration,” and a curb ramp must be constructed rather than simply replacing the curb. See 28 CFR 35.151(b) and 35.151(i).

If a public entity is unsure whether the scope of specific full-depth pavement patching constitutes an alteration, the best practice is for the public entity to work together with the State transportation agency and the FHWA Division to come to an agreement on how to consistently handle these situations and document their decisions.

Q13: Do any other requirements apply to road alteration projects undertaken by public entities that receive Federal financial assistance from DOT either directly or indirectly, even if such financial assistance is not used for the specific road alteration project at issue?

A13: Yes, if a public entity receives any Federal financial assistance from DOT whether directly or through another DOT recipient, then the entity must also apply DOT’s Section 504 requirements even if the road alteration project at issue does not use Federal funds. See 49 CFR 27.3 (applicability of DOT’s Section 504 requirements) and 27.5 (definition of “program or activity”).

DOT’s Section 504 disability nondiscrimination regulations are found at 49 CFR Part 27. These regulations implement Section 504 of the Rehabilitation Act of 1973 (Section 504). In 2006, DOT updated its accessibility standards by adopting the 2004 Americans with Disabilities Act Accessibility Guidelines (2004 ADAAG²) into its Section 504 regulations at 49 CFR 27.3 (referencing 49 CFR Part 37, Appendix A). These requirements replaced the previously applicable ADA Standards for Accessible Design (1991) (formerly known as 1991 ADAAG). At that time, DOT’s regulation adopted a modification to Section 406 of the 2004 ADAAG which required the placement of detectable warnings on curb ramps.

The revised DOT Section 504 regulation also provided a “safe harbor” provision (similar to the ADA provision discussed in Question 1) that applies to curb ramps that were newly constructed or altered by entities receiving Federal financial assistance from DOT and that were in compliance with the 1991 ADAAG requirements prior to November 29, 2006. If the “safe harbor” applies, these curb ramps are still considered compliant and do not have to be modified to add detectable warnings unless they are altered after November 29, 2006. The DOT “safe harbor” provision is found at 49 CFR 37.9(c). DOT’s Section 504 regulations (49 CFR 27.19(a)) require compliance with 49 CFR Part 37.

The Section 504 safe harbor does not apply, however, if, at the time of the road alteration project, the existing curb ramp does not comply with the 1991 ADAAG and at that time it must be brought into compliance with the current DOT Section 504 requirements (2004 ADAAG) including detectable warnings.

Q14: Does the Section 504 safe harbor apply to curb ramps built in compliance with 1991 ADAAG during the time period when the requirement for detectable warnings was suspended and the roadway is now being resurfaced where it intersects the pedestrian walkway?

A14: If the curb ramps that were built or altered prior to November 29, 2006 were fully compliant with 1991 ADAAG at the time that the detectable warnings requirements were suspended, then the DOT Section 504

safe harbor applies to them and the recipient does not have to add detectable warnings as a result of a resurfacing project.

Q15: *In addition to the obligations triggered by road resurfacing alterations, are there other title II or Section 504 requirements that trigger the obligation to provide curb ramps?*

A15: In addition to the obligation to provide curb ramps when roads are resurfaced, both DOJ's title II ADA regulation and DOT's Section 504 regulation (applicable to recipients of DOT Federal financial assistance), require the provision of curb ramps if the sidewalk is installed or altered at the intersection, during new construction, as a means of providing program accessibility, and as a reasonable modification under title II or a reasonable accommodation under Section 504.

New Construction and Alterations

DOJ's title II ADA regulation provides that newly constructed or altered streets, roads, and highways must contain curb ramps or other sloped areas at any intersection having curbs or other barriers to entry from a street level pedestrian walkway. In addition, the regulation provides that newly constructed or altered street level pedestrian walkways must contain curb ramps or other sloped areas at intersections to streets, roads, or highways. See 28 CFR 35.151(i). These curb ramps must comply with the 2010 Standards.³

DOT's Section 504 Federally assisted regulation also requires the provision of curb ramps in new construction and alterations. See 49 CFR 27.19(a) (requiring recipients of DOT financial assistance to comply with DOJ's ADA regulation at 28 CFR Part 35, including the curb ramp requirements at 28 CFR 35.151(i)); 49 CFR 27.75 (a)(2) (requiring all pedestrian crosswalks constructed with Federal financial assistance to have curb cuts or ramps).

Program Accessibility

Both DOJ's title II ADA regulation and DOT's Section 504 regulation require that public entities/recipients operate each service, program, or activity so that the service, program, or activity, when viewed in its entirety, is readily accessible to and usable by individuals with disabilities. This obligation, which is known as providing "program accessibility," includes a requirement to evaluate existing facilities in the public right-of-way for barriers to accessibility, including identifying non-existent or non-compliant curb ramps where roads intersect pedestrian access routes (sidewalks or other pedestrian walkways). After completing this self-evaluation, a public entity/recipient must set forth a plan for eliminating such barriers so as to provide overall access for persons with disabilities. See 28 CFR 35.150, and 49 CFR 27.11(c).

Since March 15, 2012, the DOJ title II regulation requires the use of the 2010 Standards for structural changes needed to provide program access. However, in accordance with the ADA safe harbor discussed in Question 1, if curb ramps constructed prior to March 15, 2012 already comply with the curb ramp requirements in the 1991 Standards, they need not be modified in accordance with the 2010 Standards in order to provide program access, unless they are altered after March 15, 2012.

Similarly, DOT's Section 504 "safe harbor" allows curb ramps that were newly constructed or altered prior to November 29, 2006, and that meet the 1991 ADAAG to be considered compliant.⁴ Elements not covered

under the safe harbor provisions may need to be modified to provide program access and should be incorporated into a program access plan for making such modifications. 49 CFR 27.11(c)(2).

Under Section 504, self-evaluations and transition plans should have been completed by December 29, 1979. Under the ADA, transition plans should have been completed by July 26, 1992, and corrective measures should have been completed by January 26, 1995. While these deadlines have long since passed, entities that did not develop a transition plan prior to those dates should begin immediately to complete their self-evaluation and develop a comprehensive transition plan.

Reasonable Modification /Accommodation

In addition to alteration and program accessibility obligations, public entities may have an obligation under title II and Section 504 to undertake curb ramp construction or alteration as a “reasonable modification/accommodation” in response to a request by, or on behalf of, someone with a disability. Such a request may be made to address a non-compliant curb ramp outside of the schedule provided in the public entity’s transition plan. A public entity must appropriately consider such requests as they are made. 28 CFR 35.130(b)(7); 49 CFR 27.7(e).

¹ The 2010 Standards can be found on DOJ’s website at

http://www.ada.gov/2010ADASTandards_index.htm.

² In 2004, the United States Architectural and Transportation Barriers Board (U.S. Access Board) published the Americans with Disabilities Act Accessibility Guidelines (2004 ADAAG), which serve as the basis of the current enforceable ADA standards adopted by both DOT and DOJ.

³ The 2010 Standards include a provision on equivalent facilitation that allows covered entities to use other designs for curb ramps if such designs provide equal or greater access. See section 103 of the [2010 Standards](#).

⁴ The DOT “safe harbor” provision is found at 49 CFR 37.9(c). DOT’s Section 504 regulations (49 CFR 27.19(a)) require compliance with 49 CFR Part 37.

The Americans with Disabilities Act authorizes the Department of Justice (the Department) to provide technical assistance to individuals and entities that have rights or responsibilities under the Act. This document provides informal guidance to assist you in understanding the ADA and the Department's regulations.

This guidance document is not intended to be a final agency action, has no legally binding effect, and may be rescinded or modified in the Department's complete discretion, in accordance with applicable laws. The Department's guidance documents, including this guidance, do not establish legally enforceable responsibilities beyond what is required by the terms of the applicable statutes, regulations, or binding judicial precedent.

December 1, 2015

Attachment D:

MnDOT Level 2 and 3 Intersection Details

City of Minneapolis: Public Works

ROW Management

2023

* Document mark ups created by MnDOT and may not reflect all current design standards of City of Minneapolis: Public Works. For reference use only for examples of level 2 and 3 designs.

EXAMPLE INTERSECTION DETAIL SHEET

Only one intersection per sheet

See MnDOT Standard Legend on ADA website

LEGEND

- XXX- CONTROL POINTS AT GUTTER FLOW LINE
- [Symbol] TRUNCATED DOMES (SEE STANDARD PLATE T038)
- [Symbol] CONSTRUCT CONCRETE CURB & GUTTER
- [Symbol] BITUMINOUS TREATMENT-SEE TABULATIONS
- X' CURB HEIGHT
- [Symbol] LANDING AREA - 4'x 4' MIN. DIMENSIONS AND MAX 2.0% SLOPE IN ALL DIRECTIONS
- [Symbol] INDICATES PEDESTRIAN RAMP - SLOPE SHALL BE BETWEEN 5.0% MINIMUM AND 8.3% MAXIMUM IN THE DIRECTION SHOWN AND CROSS SLOPE SHALL NOT EXCEED 2.0%
- [Symbol] INDICATES PEDESTRIAN RAMP - SLOPE SHALL BE GREATER THAN 2.0% AND LESS THAN 5.0% IN THE DIRECTION SHOWN AND CROSS SLOPE SHALL NOT EXCEED 2.0%
- [Symbol] DRAINAGE FLOW ARROW

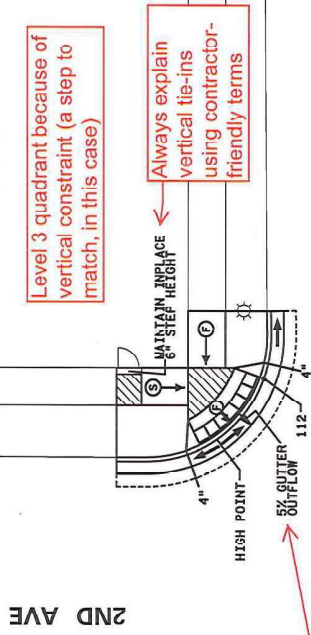

20-scale required

Level 3 quadrant because of vertical constraint (a step to match, in this case)

Always explain vertical tie-ins using contractor-friendly terms

Reverse gutter used to help make up elevation

For Level 2 quadrants, include only one Control Point on ramps. Locate this point at the outside edge of domes. Select the Trunk Highway side for depressed corner or fan ramps.

Label specific ramp slope (to the nearest full %) and length if and only when they are non-compliant

When including (x,y,z)'s for directional curb, select three points: outside edge of domes and two on the flow line.

Level 3 quadrant because of vertical constraint (an alcove to match, in this case)

POINT NUMBER	X	Y	ELEVATION
NE CORNER			
101	556102.00	149645.05	950.34
102	556098.97	149645.03	950.78
103	556098.49	149644.99	950.90
104	556098.10	149644.89	950.87
105	556098.02	149644.87	950.83
106	556092.95	149643.18	950.72
107	556092.48	149643.06	950.68
108	556092.00	149643.03	950.39
109	556077.00	149643.03	950.17
110	555990.10	149682.87	950.90
111	555952.27	149593.11	950.87
NW CORNER			
112	555990.10	149682.87	-
SE CORNER			
113	556064.73	149653.76	951.46
114	556064.73	149667.38	951.40
115	556064.66	149678.76	951.32
116	556064.73	149679.39	951.28
117	556064.92	149682.76	951.25
118	556073.81	149688.39	951.17
119	556073.17	149692.34	951.10
120	556077.17	149693.13	950.74
121	556077.17	149591.39	950.65
122	556064.73	149553.76	951.46
123	556064.73	149667.38	951.40

SEE TABULATIONS FOR CURBS.

z's provided when curb flow lines are changed vertically/horizontally

Level 3 quadrant because of vertical constraint (a step to match, in this case) and because of the non-compliant ramp slope

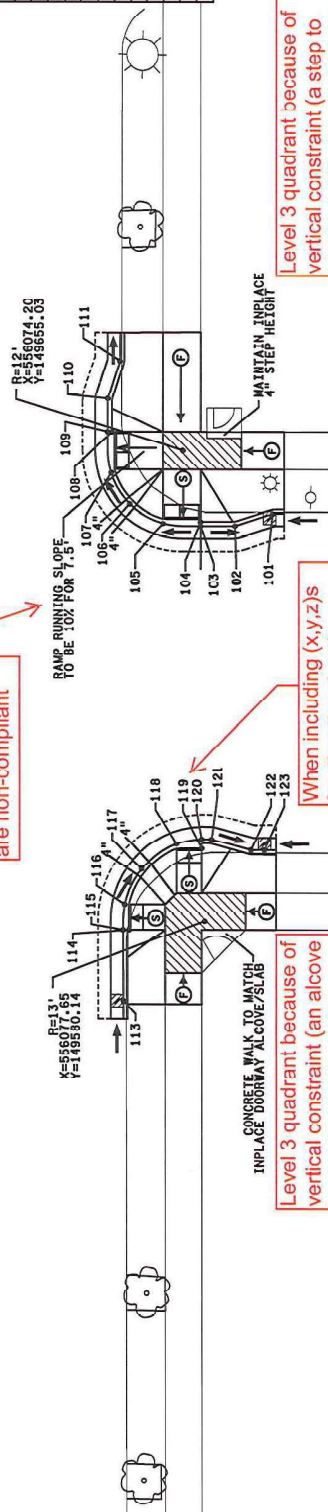

RAMP RUNNING SLOPE TO BE 10% FOR 7.5'

CONCRETE WALK TO MATCH

INTERSECTION A

INTERSECTION DETAILS

EXAMPLE INTERSECTION DETAIL SHEET

Only one intersection per sheet

PLOTTED/REVISED: 01-FEB-2013

When raising gutter flow lines, ensure that positive drainage is maintained from the road surface to the gutter.

Always explain vertical tie-ins using contractor-friendly terms

Level 3 quadrant because of vertical constraint (a step to match, in this case)

Always include this clarification to communicate that the flow line raise is an intentional design.

If a gutter profile isn't included, add this explanation of difference between in-place and proposed to the Control Points table.

(Optional) gutter profile example

Level 2 quadrant because the new ramp doesn't align with the approaching back of walk

Level 2 quadrant because the new ramp doesn't align with the approaching back of walk

Include a cross reference to Tabulation when an intersection requires both Level 1 and 2/3 designs. Do not show removals or planned construction at the Level 1 quadrant.

See MnDOT Standard Legend on ADA website

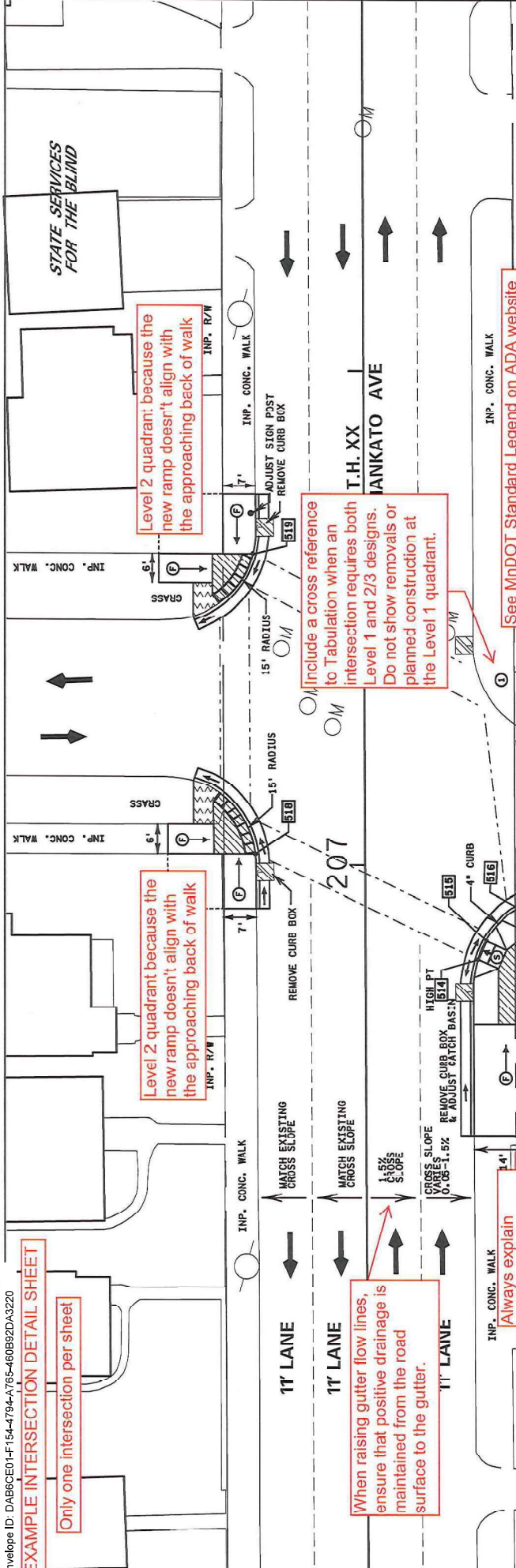

LEGEND

DETAIL POINTS

- TRUNCATED DOMES (SEE STANDARD PLATE 703B)
- CONSTRUCT CONCRETE CURB & GUTTER
- GROSSWALK
- TRAFFIC DIRECTION
- LANDING AREA - 4' X 4' MIN DIMENSIONS AND MAX 2.0% SLOPE IN ALL DIRECTIONS
- INDICATES PEDESTRIAN RAMP - SLOPE SHALL BE BETWEEN 6.0% MINIMUM AND 8.3% MAXIMUM IN THE DIRECTION SHOWN AND GROSS SLOPE SHALL NOT EXCEED 2.0%
- INDICATES PEDESTRIAN RAMP - SLOPE SHALL BE GREATER THAN 2.0% AND LESS THAN 5.0% IN THE DIRECTION SHOWN AND GROSS SLOPE SHALL NOT EXCEED 2.0%
- DRAINAGE FLOW ARROW
- REGRADE AND REPLACE WITH SOD
- 5' T.E. MEASURED FROM BACK OF SIDEWALK

GUTTER CONTROL POINTS

PT. NO. (QUAD)	X	Y	ELEVATION	
T.H. XX AND 28TH AVE NE				
514	SE	151116.5006	179802.4751	839.47
515	SE	151117.7932	179806.4751	839.44
516	SE	151122.7409	179814.0921	839.39
517	SE	151125.7129	179816.1107	839.36
518	SW	151072.4314	179827.0553	-
519	NW	151071.9900	179837.9420	-

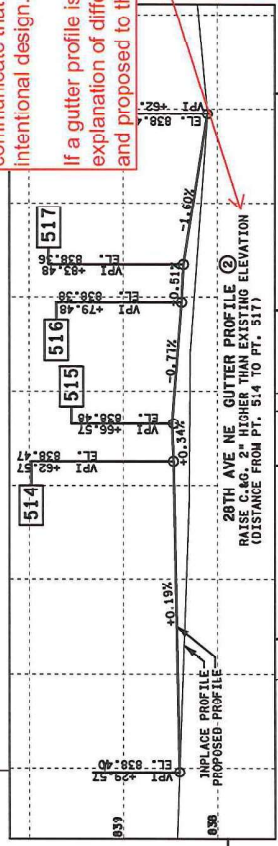

SEE TABULATION X FOR CHFB RAMP CONSTRUCTION QUANTITIES.

20-scale required

SIGNAL REPLACEMENT WITH APS EXAMPLE PLAN

Only one intersection per sheet

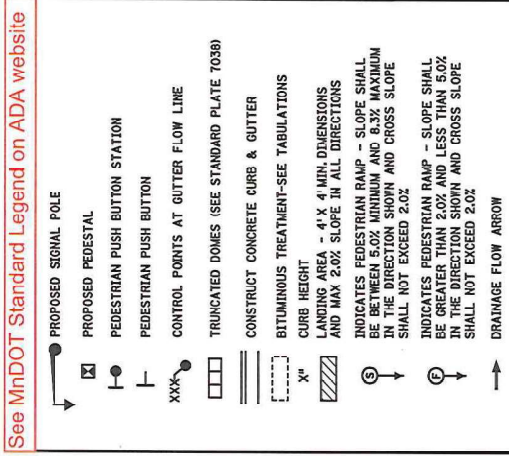
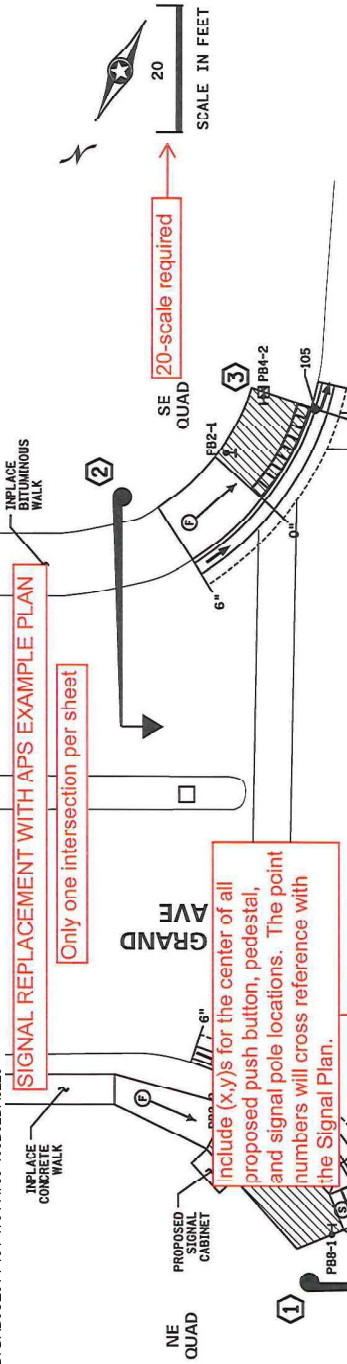

POINT NO.	X	Y	FRONT OF LANDING (FT)	DISTANCE TO BACK OF LANDING (FT)
PBB-1	555973.5471	186473.9606	2	6
PBB-2	555916.2765	186470.6400	2	6
PBB-1	555930.3465	186471.5934	3	1
PBB-2	ON POLE 3	ON POLE 3	8	2
PBB-1	555986.7955	186457.9422	1	4
PBB-2	555986.7955	186457.9422	2	7.5
PBB-1	555986.7955	186457.9422	2	4
PBB-2	ON POLE 6	ON POLE 6	2	2
POLE 1	573198.8601	253778.9766		
POLE 2	573099.5191	253689.4266		
POLE 3	573175.1256	253599.9369		
POLE 4	555986.7955	186457.9422		
POLE 5	573281.4871	253680.3464		
POLE 6	573198.8601	253778.9766		

POINT NO.	X	Y
100	556067.9106	186373.7930
101	556053.9194	186370.2730
102	555987.3742	186375.4952
103	555976.9660	186361.4794
104	555920.5656	186359.3100
105	555911.5503	186359.0742
106	555861.6673	186358.6566
107	555849.4321	186371.1055
108	555848.4949	186452.2368

For Level 2 quadrants, include only one Control Point on ramps. Locate this point at the outside edge of domes. Select the Trunk Highway side for depressed corner or fan ramps.

Distances from push button to front and back of landing included to provide for the 6 ft MAR (Maintenance Access Route), or the 4 ft minimum PAR, and to emphasize the MN MUTCD criteria that push buttons should be adjacent to a landing (and not at ramp grade breaks).

Draft ramp lengths to scale. Always explain vertical tie-ins using contractor-friendly terms

REMOVE CONC. CURB & GUTTER		REMOVE CONC. CURB & GUTTER		REMOVE CONC. CURB & GUTTER		REMOVE CONC. CURB & GUTTER		REMOVE CONC. CURB & GUTTER		REMOVE CONC. CURB & GUTTER		REMOVE CONC. CURB & GUTTER		REMOVE CONC. CURB & GUTTER		REMOVE CONC. CURB & GUTTER		REMOVE CONC. CURB & GUTTER		REMOVE CONC. CURB & GUTTER		
SR FT	LN FT	SR FT	LN FT	SR FT	LN FT	SR FT	LN FT	SR FT	LN FT	SR FT	LN FT	SR FT	LN FT	SR FT	LN FT	SR FT	LN FT	SR FT	LN FT	SR FT	LN FT	
293	4.6	110	4.6	59	4.6	276	4.6	50	4.6	197	168	893	1440	135	72	40						
NE QUAD		SE QUAD		S MEDIAN		SW QUAD		NW QUAD		TOTALS												

Quantity tabulation included only if it's a standalone signal project. ADA pay item quantities are otherwise included in the Plan Tabulations and SEQ.

- GENERAL NOTES:
- PROVIDE A SAWCUT AT THE REMOVAL LIMIT OR THE NEAREST JOINT OF THE CONCRETE WALK AND CONCRETE CURB & GUTTER. ALL SAWCUTS SHALL BE INCIDENTAL.
 - LANDINGS SHALL BE CONNECTED TO EXISTING SIDEWALKS MAINTAINING A 4' WIDE (MINIMUM) PEDESTRIAN ACCESS ROUTE WITH A CROSS SLOPE THAT DOES NOT EXCEED 2.0% AND A RUNNING SLOPE THAT DOES NOT EXCEED 8.3%.
 - ALL PERPENDICULAR RAMPS ARE 4' LONG UNLESS OTHERWISE NOTED.
 - LOCATE ALL NEW HANDHOLES OUTSIDE OF THE PAR.
 - THE OUTSIDE EDGE OF CROSSWALK MARKINGS SHALL LINE UP WITH THE OUTSIDE EDGE OF TRUNCATED DOMES.
 - SALVAGE AND INSTALL SIGN.
 - SHORTEN METEOR NOSE TO MAKE ROOM FOR NEW CROSSWALK. CONSTRUCT CONCRETE NOSE - SEE STANDARD PLATE 7113.
 - CONSTRUCT PAVEMENT TO FILL THE AREA WHERE THE CONCRETE PAVEMENT IS TO BE REMOVED. MATCH INPLACE PAVEMENT THICKNESS.

BY: DATE	REVISIONS	SYSTEM ID: 20937	T.E. 5112	S.A.P. NO.	DRAWN BY:	CHECK BY:	DATE:
		METER ADDRESS: 236 STATE HWY 156	T.E. 156	CERTIFIED BY:			
		MASTER ID: 2172C	T.E.	LIC. NO.			
				STATE PROJ. NO. XXXX-XX	(T.H. XXXX)	SHEET NO. X OF XX SHEETS	

PEDESTRIAN CROSSWALK DETAILS
TRAFFIC CONTROL SIGNAL SYSTEM
T.H. 156 AT C.S.A.H. 14 (GRAND AVE)
IN SOUTH ST. PAUL, DAKOTA COUNTY

IAPS UPGRADE EXAMPLE INTERSECTION DETAIL

Only one intersection per sheet

See MnDOT Standard Legend on ADA website

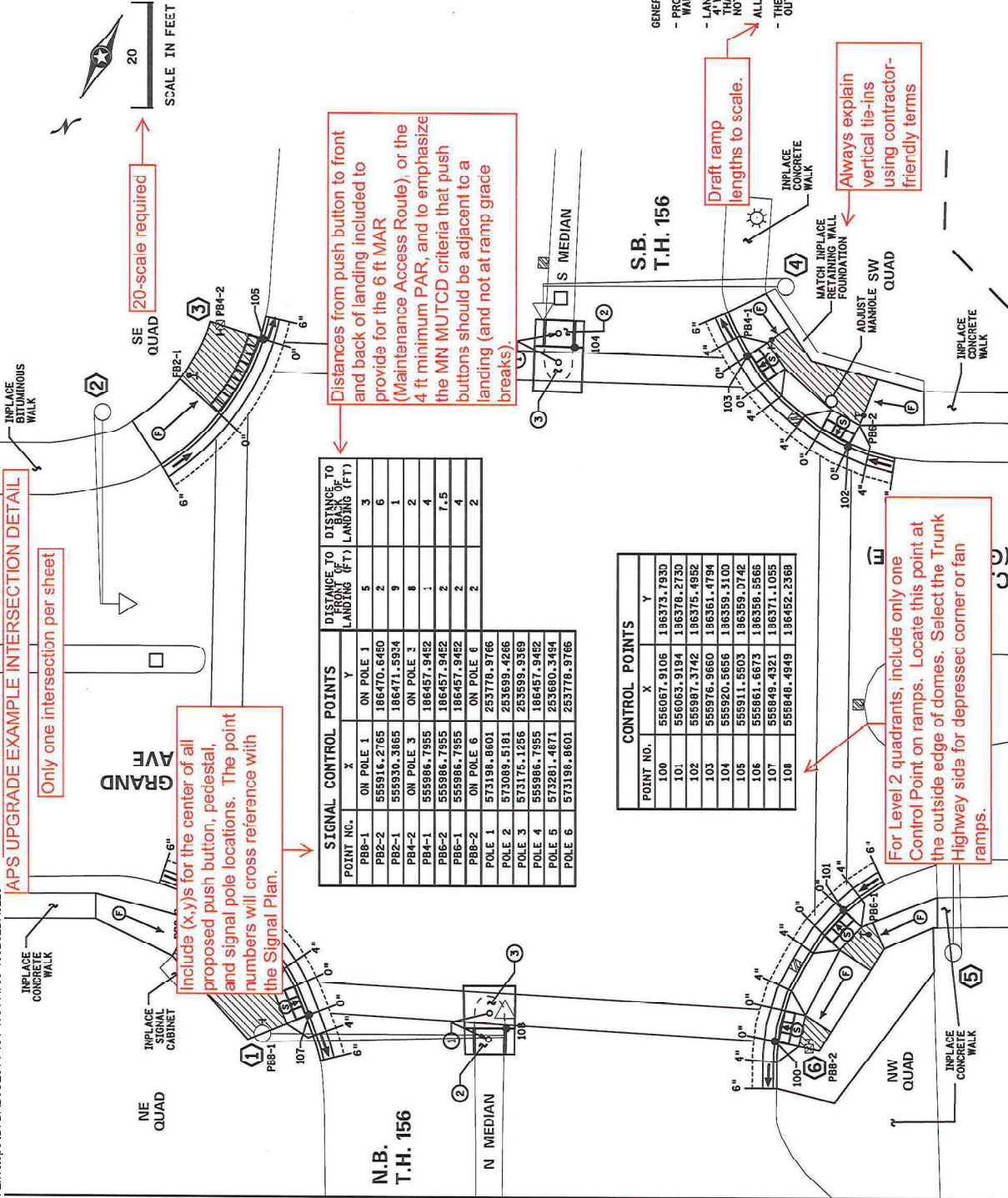
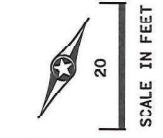

Distances from push button to front and back of landing included to provide for the 6 ft MAR (Maintenance Access Route), or the 4 ft minimum PAR, and to emphasize the MN MUTCD criteria that push buttons should be adjacent to a landing (and not at ramp grace breaks).

POINT NO.	X	Y	DISTANCE TO FRONT OF LANDING (FT)	DISTANCE TO BACK OF LANDING (FT)
PBB-1	ON POLE 1	ON POLE 1	5	3
PBB-2	555916.2765	186470.6460	2	6
PBB-1	555930.3865	186471.5934	9	1
PBB-2	ON POLE 3	ON POLE 3	8	2
PBB-1	555986.7955	186457.9422	1	4
PBB-2	555986.7955	186457.9422	2	7.5
PBB-1	555986.7955	186457.9422	2	4
PBB-2	ON POLE 6	ON POLE 6	2	2
POLE 1	573198.8601	253778.9766		
POLE 2	573089.5181	253699.4266		
POLE 3	573175.1256	253599.9369		
POLE 4	555986.7955	186457.9422		
POLE 5	573281.4871	253680.3454		
POLE 6	573198.8601	253778.9766		

POINT NO.	X	Y
100	556067.9106	186373.7930
101	556053.9194	186378.2730
102	555987.3742	186375.4992
103	555976.9660	186361.4794
104	555920.5656	186359.3100
105	555911.5503	186359.0742
106	555861.6673	186359.5565
107	555849.4321	186371.1055
108	555848.4949	186452.2368

For Level 2 quadrants, include only one Control Point on ramps. Locate this point at the outside edge of domes. Select the Trunk Highway side for depressed corner or fan ramps.

- GENERAL NOTES:**
- PROVIDE A SAWCUT AT THE REMOVAL LIMIT OR THE NEAREST JOINT OF THE CONCRETE WALK AND CONCRETE CURB & GUTTER. ALL SAWCUTS SHALL BE INCIDENTAL.
 - LANDINGS SHALL BE CONNECTED TO EXISTING SIDEWALKS MAINTAINING A 4" WIDE (MINIMUM) PEDESTRIAN ACCESS. ALL SIDEWALKS SHALL BE CONCRETE AND SHALL NOT EXCEED 8.3% IN THE DIRECTION OF CROSS SLOPE AND A RUNNING SLOPE THAT DOES NOT EXCEED 2.0%.
 - ALL PERPENDICULAR RAMP ARE 4' LONG UNLESS OTHERWISE NOTED
 - THE OUTSIDE EDGE OF CROSSWALK MARKINGS SHALL LINE UP WITH THE OUTSIDE EDGE OF TRUNCATED DOMES.
- 1 SALVAGE AND INSTALL SIGN.
 - 2 SHORTEN MEDIAN NOSE TO MAKE ROOM FOR NEW CROSSWALK. CONSTRUCT CONCRETE NOSE - SEE STANDARD PLATE 7113.
 - 3 CONSTRUCT CONCRETE PAVEMENT TO FILL THE AREA WHERE THE CONCRETE MEDIAN NOSE IS TO BE REMOVED. MATCH INPLACE PAVEMENT THICKNESS.

BY DATE	SYSTEM ID: 20937	T.E.: 5112	REVISIONS
	METER ADDRESS: 236 STATE HWY 156	T.E.: 156	
	MASTER ID: 21720	T.E.:	
S.A.F. NO.	DATE	DATE	DATE
CERTIFIED BY	L.I.C. NO.	DATE	DATE
LICENSED PROFESSIONAL ENGINEER			
STATE PROJ. NO. XXXX-XX (T.H. XXX) SHEET NO. X OF XX SHEETS			

PEDESTRIAN CROSSWALK DETAILS
TRAFFIC CONTROL SIGNAL SYSTEM
T.H. 156 AT C.S.A.H. 14 (GRAND AVE.)
IN SOUTH ST. PAUL, DAKOTA COUNTY

CONTROL POINTS		
X	Y	Z
100	512723.43	212898.65
101	512723.06	212905.25
102	512729.79	212912.65
103	512729.57	212916.43
104	512734.67	212916.76
105	512719.34	212898.65
106	512717.31	212898.65
107	512718.46	212898.65
108	512718.01	212916.86
109	512718.87	212915.43
110	512719.23	212910.02
111	512719.47	212902.43
112	512722.99	212908.48

LEVEL 3 ISLAND (A.K.A. PORK CHOP) EXAMPLE DETAIL

All quadrants on this sheet would ordinarily contain Level 2/3 details in addition to the pork chop detail.

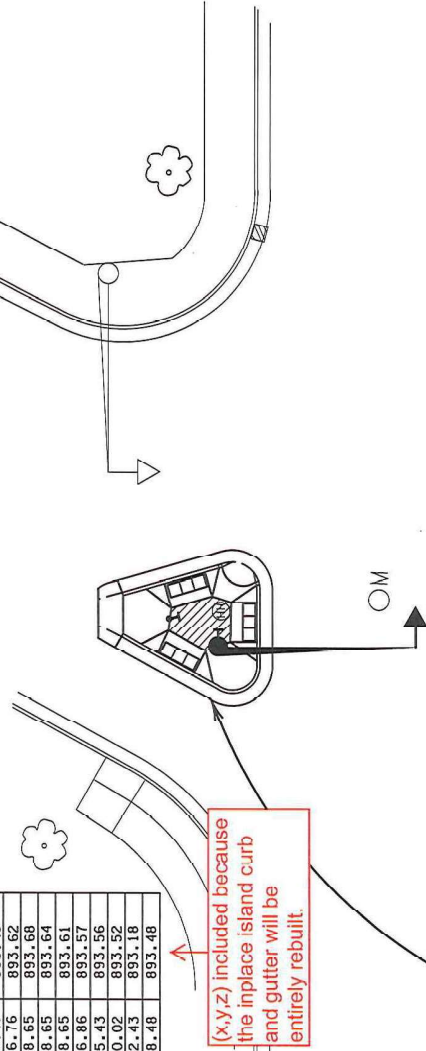

(x,y,z) included because the in-place island curb and gutter will be entirely rebuilt.

10-scale used to display details only because ramp slopes couldn't fit in on a 20-scale

4" curb height preferred for islands. 4" curb height required if design speed is 45 mph or greater, in accordance with Road Design Manual 4-4.04.

(x,y,z) on the landing applies because of the reconstruction scope. The control point on the landing is included only for and for all reconstruction projects.

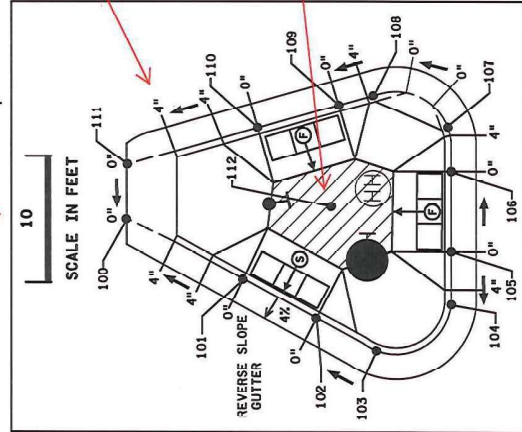

See MnDOT Standard Legend on ADA website

LEGEND

- INPLACE SIGNAL POLE
- PROPOSED SIGNAL POLE
- PEDESTRIAN PUSH BUTTON STATION
- PEDESTRIAN PUSH BUTTON
- CONTROL POINTS AT GUTTER FLOW LINE
- TRUNCATED DOWNS (SEE STANDARD PLATE 7033)
- CONSTRUCT CONCRETE CURB & GUTTER
- CURB HEIGHT
- LANDING AREA - 4' X 4' MIN. DIMENSIONS AND MAX 2.0% SLOPE IN ALL DIRECTIONS
- INDICATES PEDESTRIAN RAMP - SLOPE SHALL BE BETWEEN 5.0% MINIMUM AND 6.3% MAXIMUM IN THE DIRECTION SHOWN AND CROSS SLOPE SHALL NOT EXCEED 2.0%
- INDICATES PEDESTRIAN RAMP - SLOPE SHALL BE GREATER THAN 2.0% AND LESS THAN 5.0% IN THE DIRECTION SHOWN AND CROSS SLOPE SHALL NOT EXCEED 2.0%
- DRAINAGE FLOW ARROW

CONSTRUCTION PLAN DETAILS
SAMPLE PLAN

CERTIFIED BY _____ LIC. NO. _____ DATE _____

Attachment E:

2015 City Engineer's Memo

Pedestrian Restoration Policy

City of Minneapolis: Public Works

ROW Management

2023



Public Works
350 S. Fifth St. - Room 203
Minneapolis, MN 55415
TEL 612.673.2352
www.minneapolismn.gov

Andrew Balgobin
CenterPoint Energy
700 West Linden Avenue
PO Box 1165
Minneapolis, MN 55440

September 28, 2015

Dear Mr. Balgobin,

RE: Pedestrian Ramp Restoration Policy

The City of Minneapolis is currently undertaking an effort to update its policies and procedures related to ADA Title II accessibility. As part of this initiative, it has come to my attention that sidewalk replacement work performed by utility companies following a right of way excavation triggers ADA compliance. This means that any city sidewalk ramp altered in any way by your company must be rebuilt to current ADA standards, regardless of the sidewalk's preexisting physical condition.

I am writing to request that Centerpoint Energy, along with all utility companies working in the City of Minneapolis, follow the practice of restoring city sidewalks and pedestrian ramps to current ADA standards whenever a sidewalk is altered by a utility excavation. This is the current practice among the City's own construction and maintenance operations, permitted real estate developers, and all other non-franchised utilities working within the City's boundaries. Moreover, the same practice has been adopted by MnDOT with respect to alterations of state-owned infrastructure.

The City of Minneapolis is adopting this policy as of the date of this letter, and I am requesting your support and cooperation as soon as practicably feasible. The City of Minneapolis Public Works Department continues to adopt the current version of the MnDOT Pedestrian Ramp Standard (5-297.250) dated August 6, 2014. If you have questions or concerns about any of the foregoing, please do not hesitate to contact me or Paul Ogren at 612-673-3403.

Sincerely,

A handwritten signature in blue ink, appearing to read "Steve Kotke", written over a white background.

Steve Kotke
Director/City Engineer
Minneapolis Public Works

cc: Paul Ogren



Public Works
350 S. Fifth St. - Room 203
Minneapolis, MN 55415
TEL 612.673.2352
www.minneapolismn.gov

James Nash, P.E.
Xcel Energy
1518 Chestnut Ave
Minneapolis, MN 55403

September 28, 2015

Dear Mr. Nash,

RE: Pedestrian Ramp Restoration Policy

The City of Minneapolis is currently undertaking an effort to update its policies and procedures related to ADA Title II accessibility. As part of this initiative, it has come to my attention that sidewalk replacement work performed by utility companies following a right of way excavation triggers ADA compliance. This means that any city sidewalk ramp altered in any way by your company must be rebuilt to current ADA standards, regardless of the sidewalk's preexisting physical condition.

I am writing to request that Xcel Energy, along with all utility companies working in the City of Minneapolis, follow the practice of restoring city sidewalks and pedestrian ramps to current ADA standards whenever a sidewalk is altered by a utility excavation. This is the current practice among the City's own construction and maintenance operations, permitted real estate developers, and all other non-franchised utilities working within the City's boundaries. Moreover, the same practice has been adopted by MnDOT with respect to alterations of state-owned infrastructure.

The City of Minneapolis is adopting this policy as of the date of this letter, and I am requesting your support and cooperation as soon as practicably feasible. The City of Minneapolis Public Works Department continues to adopt the current version of the MnDOT Pedestrian Ramp Standard (5-297.250) dated August 6, 2014. If you have questions or concerns about any of the foregoing, please do not hesitate to contact me or Paul Ogren at 612-673-3403.

Sincerely:

A handwritten signature in blue ink, appearing to read "Steve Kotke".

Steve Kotke
Director/City Engineer
Minneapolis Public Works

cc: Paul Ogren



Public Works
350 S. Fifth St. - Room 203
Minneapolis, MN 55415
TEL 612.673.2352
www.minneapolismn.gov

Duane Carlson
Vice President of Construction
Comcast Cable Communications, Incorporated
2621 Fairview Avenue N
Roseville, MN 55113

September 28, 2015

Dear Mr. Carlson,

RE: Pedestrian Ramp Restoration Policy

The City of Minneapolis is currently undertaking an effort to update its policies and procedures related to ADA Title II accessibility. As part of this initiative, it has come to my attention that sidewalk replacement work performed by utility companies following a right of way excavation triggers ADA compliance. This means that any city sidewalk ramp altered in any way by your company must be rebuilt to current ADA standards, regardless of the sidewalk's preexisting physical condition.

I am writing to request that Comcast, along with all utility companies working in the City of Minneapolis, follow the practice of restoring city sidewalks and pedestrian ramps to current ADA standards whenever a sidewalk is altered by a utility excavation. This is the current practice among the City's own construction and maintenance operations, permitted real estate developers, and all other non-franchised utilities working within the City's boundaries. Moreover, the same practice has been adopted by MnDOT with respect to alterations of state-owned infrastructure.

The City of Minneapolis is adopting this policy as of the date of this letter, and I am requesting your support and cooperation as soon as practicably feasible. The City of Minneapolis Public Works Department continues to adopt the current version of the MnDOT Pedestrian Ramp Standard (5-297.250) dated August 6, 2014. If you have questions or concerns about any of the foregoing, please do not hesitate to contact me or Paul Ogren at 612-673-3403.

Sincerely:

A handwritten signature in blue ink, appearing to read "Steve Kotke", written over a white background.

Steve Kotke
Director/City Engineer
Minneapolis Public Works

cc: Paul Ogren